

## A Wide Non-Trivially Associated Tensor Category

M. M. Al-Mosa Al-Shomrani

*Department of Mathematics, Faculty of Science,  
King Abdulaziz University, Jeddah  
P. O. Box 80257, Jeddah 21589, Saudi Arabia*

*Abstract.* In this paper we introduce a new category  $\bar{\mathcal{C}}$  by adding new morphisms to a non-trivially associated tensor category  $\mathcal{C}$ . Then, the properties of these morphisms are studied and an example is given. Finally, the relationship between the categories  $\mathcal{C}$  and  $\bar{\mathcal{C}}$  is derived.

### Introduction

The fact that a Hopf algebra  $H = kM \bowtie k(G)$  can be constructed for every factorization  $X = GM$  of a group into two subgroups  $G$  and  $M$ , is well known. This bicrossproduct construction is one of the sources of true non-commutative and non-cocommutative Hopf algebras [1].

These bicrossproduct Hopf algebras have been studied intensively by Beggs, Gould and Majid in [2&3]. Beggs [4] has considered more general factorizations of groups, and their corresponding algebras. More specifically, it was shown that it is possible to construct a non-trivially associated tensor category  $\mathcal{C}$  from data which is a choice of left coset representatives  $M$  for a subgroup  $G$  of a finite group  $X$  [2-7]. The objects of this category are the right representations of  $G$  that possess  $M$ -grading. The group action and the grading in the definition of  $\mathcal{C}$  were combined by considering a single object  $A$  spanned by a basis  $\delta_m \otimes g$  for  $m \in M$  and  $g \in G$ . This object  $A$  was shown to be an

algebra in  $\mathcal{C}$  under certain conditions.

There is also a double construction, where  $X$  is viewed as a subgroup of a larger group. This gives rise to a braided category  $\mathcal{D}$ , which is the category of representations of an algebra  $D$  which combine both actions and grading in the definition of  $\mathcal{D}$  and which is itself in the category. Moreover,  $D$  was shown to be a braided Hopf algebra [4].

Al-Shomrani [6] showed that it is possible to put a  $G$ -grade and  $M$ -action on the algebra  $A$  so that it becomes an object in the braided tensor category  $\mathcal{D}$ . However the action  $\bar{\varpi} : V \otimes A \rightarrow V$  of  $A$  on objects in  $\mathcal{D}$  is not a morphism in  $\mathcal{D}$ . This raises the a natural question: Is the algebra  $A$  in  $\mathcal{D}$  a braided Hopf algebra? In general, the answer is negative. So we introduce a wide category  $\bar{\mathcal{C}}$  by adding new morphisms to the category  $\mathcal{C}$  to see if, assuming that  $A$  lives in this category, the situation is going to be different.

In this paper we use the same formulas and ideas given by Beggs [4], which is based on Ref. [2&3]. Throughout the paper, we assume that all mentioned groups are finite, and that all vector spaces are finite dimensional over a field  $k$ .

### Preliminaries

The notion of braided category plays an important role in quantum group theory and the idea of Hopf algebras in braided categories goes back to Milnor and Moore [8]. Majid [9] studies Hopf algebras in braided categories under the name "braided groups" with an algebraic motivation as well as many motivations from physics [10].

A morphism  $T : V \rightarrow W$ , a tensor product  $F : V \otimes W \rightarrow Y$ , the braid  $\Psi_{V,W} : V \otimes W \rightarrow W \otimes V$ , the braid inverse  $(\Psi_{W,V})^{-1} : V \otimes W \rightarrow W \otimes V$  and the maps  $\text{ev}_V : V^* \otimes V \rightarrow k$  and  $\text{coev}_V : k \rightarrow V \otimes V^*$  in tensor categories are represented in terms of diagrams as in Fig.1.

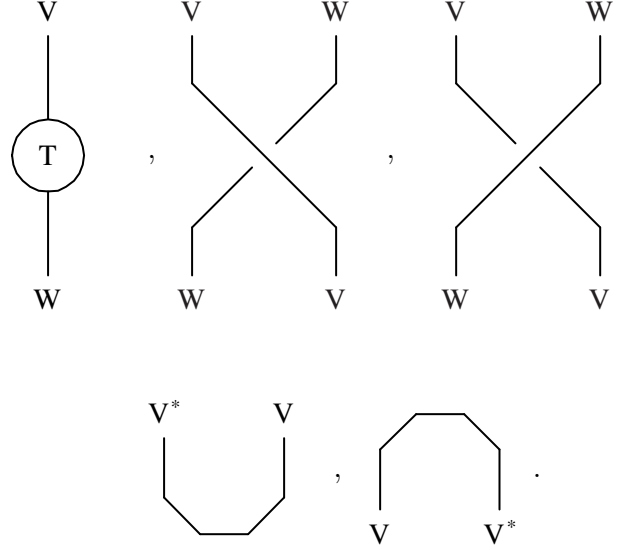

Fig. 1.

In order to make the paper self contained, we include the following useful definitions and results of Ref. [4].

**Definition 1**

For a group  $X$ , consider the factorization  $X = GM$  where  $G$  is a subgroup of  $X$  and  $M \subset X$  is a set of left coset representatives for  $G$  in  $X$ . For  $x \in X$  the factorization  $x = gm$  for  $g \in G$  and  $m \in M$  is unique. For  $m_1, m_2 \in M$ , define  $\tau(m_1, m_2) \in G$  and  $(m_1 \cdot m_2) \in M$  as well as the functions  $\triangleright : M \times G \rightarrow G$  and  $\triangleleft : M \times G \rightarrow M$  by the unique factorizations in  $X$ :  $m_1 m_2 = \tau(m_1, m_2)(m_1 \cdot m_2)$  and  $mg = (m \triangleright g)(m \triangleleft g)$  for  $m, m \triangleleft g \in M$  and  $g, m \triangleright g \in G$ .  $e$  is the identity of  $X$ .

The following identities are satisfied:

$$\begin{aligned}
 m_1 \triangleright (m_2 \triangleright g) &= \tau(m_1, m_2)((m_1 \cdot m_2) \triangleright g) \tau(m_1 \triangleleft (m_2 \triangleright g), m_2 \triangleleft g)^{-1}, \\
 (m_1 \cdot m_2) \triangleleft g &= (m_1 \triangleleft (m_2 \triangleright g)) \cdot (m_2 \triangleleft g), \\
 m \triangleright g_1 g_2 &= (m \triangleright g_1)((m \triangleleft g_1) \triangleright g_2) \quad , \quad m \triangleleft g_1 g_2 = (m \triangleleft g_1) \triangleleft g_2,
 \end{aligned}$$

$$\begin{aligned} \tau(m_1, m_2)\tau(m_1 \cdot m_2, m_3) &= (m_1 \triangleright \tau(m_2, m_3))\tau(m_1 \triangleleft \tau(m_2, m_3), m_2 \cdot m_3) \\ &= (m_1 \triangleleft \tau(m_2, m_3)) \cdot (m_2 \cdot m_3) = (m_1 \cdot m_2) \cdot m_3, \\ e \triangleleft g &= e, \quad e \triangleright g = g, \quad m \triangleright e = e, \quad m \triangleleft e = m, \end{aligned}$$

for  $m_1, m_2, m_3, m \in M$  and  $g_1, g_2, g \in G$ .

(1)

The category  $\mathcal{C}$  is defined to be a category of finite dimensional vector spaces over a field  $k$ , whose objects are right representations of the group  $G$  and have  $M$ -gradings, *i.e.*, an object  $V$  can be written as  $\bigoplus_{m \in M} V_m$ . The action for the representation is written as  $\bar{\triangleright} : V \times G \rightarrow V$ . For  $v \in V$ , the grading is denoted and defined by  $\langle v \rangle = m$  if  $v \in V_m$ . In addition, it is supposed that the action and the grading satisfy the compatibility condition, *i.e.*,  $\langle v \bar{\triangleright} g \rangle = \langle v \rangle \triangleleft g$ . The morphisms in the category  $\mathcal{C}$  is defined to be linear maps which preserve both the grading and the action, *i.e.*, for a morphism  $\vartheta : V \rightarrow W$  we have  $\langle \vartheta(v) \rangle = \langle v \rangle$  and  $\vartheta(v) \bar{\triangleright} g = \vartheta(v \bar{\triangleright} g)$  for all  $v \in V$  and  $g \in G$ .  $\mathcal{C}$  is a tensor category with action and grading given by

$$\langle v \otimes w \rangle = \langle v \rangle \cdot \langle w \rangle \quad \text{and} \quad (v \otimes w) \bar{\triangleright} g = v \bar{\triangleright} (\langle w \rangle \triangleright g) \otimes w \bar{\triangleright} g.$$

There is an associator  $\Phi_{UVW} : (U \otimes V) \otimes W \rightarrow U \otimes (V \otimes W)$  given by

$$\Phi((u \otimes v) \otimes w) = u \bar{\triangleright} \tau(\langle v \rangle, \langle w \rangle) \otimes (v \otimes w).$$

The dual object of  $V \in \mathcal{C}$  is of the form  $V^* = \bigoplus_{m \in M} V_{m^L}^*$ , and we define  $\langle \alpha \rangle = m^L$  when  $\alpha \in V_{m^L}^*$ . The evaluation map  $\text{ev} : V^* \otimes V \rightarrow k$  is defined by  $\text{ev}(\alpha, v) = \alpha(v) = (\alpha \bar{\triangleright} (\langle v \rangle \triangleright g))(v \bar{\triangleright} g)$ , or if we put  $w = v \bar{\triangleright} g$  we get the following formula:

$$\alpha(w \bar{\triangleright} g^{-1}) = (\alpha \bar{\triangleright} ((\langle w \rangle \triangleleft g^{-1}) \triangleright g))(w) = (\alpha \bar{\triangleright} (\langle w \rangle \triangleright g^{-1})^{-1})(w). \quad (2)$$

The coevaluation map, which is a morphism in  $\mathcal{C}$  is defined by

$$\text{coev}(1) = \sum_{v \in \text{basis}} v \bar{\triangleright} \tau(\langle v \rangle^L, \langle v \rangle)^{-1} \otimes \hat{v},$$

where  $\hat{v}$  is a corresponding dual basis of  $v \in V_m$ ,  $\forall m \in M$ .

The algebra  $A$  in the tensor category  $\mathcal{C}$  is constructed so that the group action and the grading in the definition of  $\mathcal{C}$  can be combined. Consider a single object  $A$ , a vector space spanned by a basis  $\delta_m \otimes g$  for  $m \in M$  and  $g \in G$ . For any object  $V$  in  $\mathcal{C}$  define a map  $\bar{\triangleleft} : V \otimes A \rightarrow V$  by  $v\bar{\triangleleft}(\delta_m \otimes g) = \delta_{m, \langle v \rangle} v\bar{\triangleleft}g$ . This map is a morphism in  $\mathcal{C}$  only if  $\langle v \rangle \cdot \langle \delta_m \otimes g \rangle = \langle v\bar{\triangleleft}g \rangle$  i.e.  $m \cdot \langle \delta_m \otimes g \rangle = m\triangleleft g$  if  $\langle v \rangle = m$ . If we put  $m_1 = \langle \delta_m \otimes g \rangle$ , the action of  $g_1 \in G$  is given by  $(\delta_m \otimes g)\bar{\triangleleft}g_1 = \delta_{m\triangleleft(m_1\triangleright g_1)} \otimes (m_1\triangleright g_1)^{-1} g g_1$ .

Next, the braided tensor category  $\mathcal{D}$  is obtained from the category  $\mathcal{C}$  by considering additional structures of a function  $\bar{\triangleright} : M \otimes V \rightarrow V$  and a  $G$ -grading  $|v| \in G$  for  $v \in V$  in  $\mathcal{D}$ . The following connections between the gradings and actions are required:

$$\begin{aligned} |v\bar{\triangleleft}g| &= (\langle v \rangle \triangleright g)^{-1} |v|g, \quad m \cdot \langle v \rangle = \langle m\bar{\triangleright}v \rangle \cdot (m\triangleleft|v|), \\ \tau(m, \langle v \rangle)^{-1} (m\triangleright|v|) &= \tau(\langle m\bar{\triangleright}v \rangle, m\triangleleft|v|)^{-1} |m\bar{\triangleright}v|. \end{aligned} \quad (3)$$

The operation  $\bar{\triangleright}$  is an action of  $M$ , which is defined to mean that  $m\bar{\triangleright} : V \rightarrow V$  is linear for all objects  $V$  in  $\mathcal{D}$  and all  $m \in M$ , and satisfies

$$m_1\bar{\triangleright}(m_2\bar{\triangleright}v) = ((m_3 \cdot m_2)\bar{\triangleright}v)\bar{\triangleleft}\tau(m_3\triangleleft(m_2\triangleright|v|), m_2\triangleleft|v|)^{-1}, \quad (4)$$

for any  $v \in V$ , where  $m_3 = m_1\triangleleft\tau(\langle m_2\bar{\triangleright}v \rangle, m_2\triangleleft|v|)\tau(m_2, \langle v \rangle)^{-1}$ . The following cross relation between the two actions is also required:

$$(m\bar{\triangleright}v)\bar{\triangleleft}((m\triangleleft|v|)\triangleright g) = (m\triangleleft(\langle v \rangle \triangleright g))\bar{\triangleright}(v\bar{\triangleleft}g). \quad (5)$$

Note that the morphisms in the category  $\mathcal{D}$  are linear maps preserving both gradings and both actions. From the conditions above, the connections between the gradings and the actions can be given by the following factorizations in  $X$ :

$$|m\bar{\triangleright}v|^{-1} \langle m\bar{\triangleright}v \rangle = (m\triangleleft|v|)|v|^{-1} \langle v \rangle (m\triangleleft|v|)^{-1}, \quad |v\bar{\triangleleft}g|^{-1} \langle v\bar{\triangleleft}g \rangle = g^{-1} |v|^{-1} \langle v \rangle g. \quad (6)$$

To make  $\mathcal{D}$  into a tensor category, the  $G$ -grading and the  $M$ -action

on the tensor products are given as follows:

$$\begin{aligned} |v \otimes w| &= \tau(\langle v \rangle, \langle w \rangle)^{-1} |v| |w|, \\ (m \triangleleft \tau(\langle v \rangle, \langle w \rangle)) \bar{\triangleright} (v \otimes w) &= (m \bar{\triangleright} v) \bar{\triangleleft} \tau(m \triangleleft |v|, \langle w \rangle) \\ &\quad \tau(\langle (m \triangleleft |v|) \bar{\triangleright} w \rangle, m \triangleleft |v| |w|)^{-1} \otimes (m \triangleleft |v|) \bar{\triangleright} w. \end{aligned}$$

Moreover, the gradings on the tensor product  $V \otimes W$  of objects  $V$  and  $W$  in  $\mathcal{D}$  are given by the following factorization in  $X$ :  $|v \otimes w|^{-1} \langle v \otimes w \rangle = |w|^{-1} |v|^{-1} \langle v \rangle \langle w \rangle$ .

These gradings are consistent with the actions as specified in (6), and the function  $\bar{\triangleright}$  applied to  $V \otimes W$  satisfies the condition (4) to be an  $M$ -action. In addition, the functions  $\bar{\triangleright}$  and  $\bar{\triangleleft}$  satisfy the cross relation (5) on  $V \otimes W$ .

The double construction is defined for a given set  $Y$ , which is identical to the group  $X$ , with a binary operation  $\circ$  by

$$(g_1 m_1) \circ (g_2 m_2) = g_2 g_1 m_1 m_2 = g_2 g_1 m_1 m_2 \tau(m_1, m_2) (m_1 \cdot m_2),$$

for  $g_1, g_2 \in G$  and  $m_1, m_2 \in M$ . The functions  $\tilde{\triangleleft} : Y \times X \rightarrow Y$  and  $\tilde{\triangleright} : Y \times Y \rightarrow X$  are defined by  $y \tilde{\triangleleft} x = x^{-1} y x$  and  $\tilde{\triangleright}(g_1 m_1, g_2 m_2) = \tau(m_1, m_2)$  for  $x \in X$  and  $y \in Y$ . Also, we define the function  $\tilde{\triangleright} : Y \times X \rightarrow X$  by

$$g_1 m_1 \tilde{\triangleright} g_2 m_2 = g_1^{-1} g_2 m_2 g_1' = m_1 g_2 m_2 m_1'^{-1},$$

where  $g_1 m_1 \tilde{\triangleleft} g_2 m_2 = g_1' m_1'$ ,  $g_1, g_1', g_2 \in G$  and  $m_1, m_1', m_2 \in M$ .

A  $Y$  valued grading on the objects of  $\mathcal{D}$  is given by  $\|v\| = |v|^{-1} \langle v \rangle$  and the  $X$ -action on the objects of  $\mathcal{D}$  is given by  $v \hat{\triangleleft} g m = (v \tilde{\triangleleft} g) \hat{\triangleleft} m$  for  $g \in G$  and  $m \in M$ , where

$$v \hat{\triangleleft} m = ((m^L \triangleleft |v|^{-1}) \bar{\triangleright} v) \bar{\triangleleft} \tau(m^L, m) \text{ and } x = g m.$$

The braiding  $\Psi$ , in terms of the  $X$ -action, is given by

$$\Psi(v \otimes w) = w \hat{\triangleleft} (\langle v \rangle \triangleleft |w|)^{-1} \otimes v \hat{\triangleleft} |w|, \quad \Psi^{-1}(v \otimes w) = w \hat{\triangleleft} |v \hat{\triangleleft} \langle w \rangle|^{-1} \otimes v \hat{\triangleleft} \langle w \rangle.$$

### The Wide Category $\bar{\mathcal{C}}$

The idea behind considering this wide category is a result of the work of Al-Shomrani in [6], where he showed that it is possible to put a  $G$ -grade and  $M$ -action on the algebra  $A$  so that it becomes an object in the braided tensor category  $\mathcal{D}$ . However the action  $\bar{\triangleright} : V \otimes A \rightarrow V$  of  $A$  on objects in  $\mathcal{D}$  is not a morphism in  $\mathcal{D}$ . This raises the a natural question: Is the algebra  $A$  in  $\mathcal{D}$  a braided Hopf algebra? In general, the answer is negative. So we introduce the wide category to see if, assuming that  $A$  lives in this category, the situation is going to be different.

If  $V$  and  $W$  in  $\mathcal{C}$  and a morphism  $\mathfrak{h} : V \rightarrow W$  satisfying:

$$\langle \mathfrak{h}(v) \rangle = \langle v \rangle \quad \text{and} \quad \mathfrak{h}(v\bar{\triangleright}g) = \mathfrak{h}(v)\bar{\triangleright}g,$$

for  $v \in V$  and  $g \in G$ , then the morphism  $\mathfrak{h}$  is in  $\mathcal{C}$ . In this case we call  $\mathfrak{h} : V \rightarrow W$  a type  $\mathcal{C}$  morphism.

Now, in order to make a new category  $\bar{\mathcal{C}}$  by adding new morphisms to the category  $\mathcal{C}$ , we define:

#### Definition 2

For objects  $V$  and  $W$  in  $\mathcal{C}$ , a linear map  $\mathfrak{f} : V \rightarrow W$  satisfying:

$$\langle \mathfrak{f}(v) \rangle = \langle v \rangle^L \quad \text{and} \quad \mathfrak{f}(v\bar{\triangleright}g) = \mathfrak{f}(v)\bar{\triangleright}(\langle v \rangle \triangleright g),$$

for  $v \in V$  and  $g \in G$ , is called a type  $\bar{\mathcal{C}}$  morphism.

It is noted that the objects of  $\bar{\mathcal{C}}$  are the same as the objects of  $\mathcal{C}$ .

We assume that  $m^{LL} = m$  and  $m^{L\triangleright}(m\triangleright g) = g$  for  $m \in M$  and  $g \in G$ . The next theorems give some properties of type  $\bar{\mathcal{C}}$  morphisms.

#### Theorem 3

Let  $\mathfrak{f} : V \rightarrow \widehat{V}$  and  $\mathfrak{g} : W \rightarrow \widehat{W}$  be type  $\bar{\mathcal{C}}$  morphisms. Then the map  $\mathfrak{f} \times \mathfrak{g} : V \otimes W \rightarrow \widehat{W} \otimes \widehat{V}$  defined by

$$(\mathfrak{f} \times \mathfrak{g})(v \otimes w) = (\mathfrak{g}(w)\bar{\triangleright}\tau(m_1^L, m_1)^{-1} \otimes \mathfrak{f}(v))\bar{\triangleright}\tau(m_1, m_2),$$

is a type  $\bar{\mathcal{C}}$  morphism, where  $v \in V$ ,  $w \in W$ ,  $m_1 = \langle v \rangle$  and  $m_2 = \langle w \rangle$ .

**Proof**

We start by calculating  $\langle (\mathbf{f} \times \mathbf{g})(v \otimes w) \rangle$ . For this we have

$$\begin{aligned}
& \langle (\mathbf{g}(w) \bar{\triangleleft} \tau(m_1^L, m_1)^{-1} \otimes \mathbf{f}(v)) \bar{\triangleleft} \tau(m_1, m_2) \rangle \\
&= \langle (\mathbf{g}(w) \bar{\triangleleft} \tau(m_1^L, m_1)^{-1} \otimes \mathbf{f}(v)) \triangleleft \tau(m_1, m_2) \rangle \\
&= \langle (\mathbf{g}(w) \bar{\triangleleft} \tau(m_1^L, m_1)^{-1}) \cdot \langle \mathbf{f}(v) \rangle \rangle \triangleleft \tau(m_1, m_2) \\
&= \langle (\langle \mathbf{g}(w) \rangle \triangleleft \tau(m_1^L, m_1)^{-1}) \cdot \langle \mathbf{f}(v) \rangle \rangle \triangleleft \tau(m_1, m_2) \\
&= \langle (\langle w \rangle^L \triangleleft \tau(m_1^L, m_1)^{-1}) \cdot \langle v \rangle^L \rangle \triangleleft \tau(m_1, m_2) \\
&= \langle (m_2^L \triangleleft \tau(m_1^L, m_1)^{-1}) \cdot m_1^L \rangle \triangleleft \tau(m_1, m_2).
\end{aligned}$$

Applying  $\cdot (m_1 \cdot m_2)$  to the right hand side of the above equation and using the associator map yield

$$\langle (\mathbf{f} \times \mathbf{g})(v \otimes w) \rangle = (m_1 \cdot m_2)^L = \langle v \otimes w \rangle^L.$$

Next, we have to show that

$$(\mathbf{f} \times \mathbf{g})((v \otimes w) \bar{\triangleleft} g) = ((\mathbf{f} \times \mathbf{g})(v \otimes w)) \bar{\triangleleft} (\langle v \otimes w \rangle \triangleright g). \quad (7)$$

We start with the left hand side of (7) as follows:

$$\begin{aligned}
(\mathbf{f} \times \mathbf{g})((v \otimes w) \bar{\triangleleft} g) &= (\mathbf{f} \times \mathbf{g})(v \bar{\triangleleft} (\langle w \rangle \triangleright g) \otimes w \bar{\triangleleft} g) \\
&= (\mathbf{f} \times \mathbf{g})(v \bar{\triangleleft} (m_2 \triangleright g) \otimes w \bar{\triangleleft} g) \\
&= \left( \mathbf{g}(w \bar{\triangleleft} g) \bar{\triangleleft} \tau((m_1 \triangleleft (m_2 \triangleright g))^L, m_1 \triangleleft (m_2 \triangleright g)) \right)^{-1} \\
&\quad \otimes \mathbf{f}(v \bar{\triangleleft} (m_2 \triangleright g)) \bar{\triangleleft} \tau(m_1 \triangleleft (m_2 \triangleright g), m_2 \triangleleft g) \\
&= \left( (\mathbf{g}(w) \bar{\triangleleft} (\langle w \rangle \triangleright g)) \bar{\triangleleft} \tau((m_1 \triangleleft (m_2 \triangleright g))^L, m_1 \triangleleft (m_2 \triangleright g)) \right)^{-1} \\
&\quad \otimes \mathbf{f}(v) \bar{\triangleleft} (\langle v \rangle \triangleright (m_2 \triangleright g)) \bar{\triangleleft} \tau(m_1 \triangleleft (m_2 \triangleright g), m_2 \triangleleft g) \\
&= \left( (\mathbf{g}(w)) \bar{\triangleleft} (m_2 \triangleright g) \tau((m_1 \triangleleft (m_2 \triangleright g))^L, m_1 \triangleleft (m_2 \triangleright g)) \right)^{-1} \\
&\quad \otimes \mathbf{f}(v) \bar{\triangleleft} (m_1 \triangleright (m_2 \triangleright g)) \bar{\triangleleft} \tau(m_1 \triangleleft (m_2 \triangleright g), m_2 \triangleleft g).
\end{aligned}$$



On the other hand,

$$\begin{aligned}
 ((\mathbf{f} \times \mathbf{g})(v \otimes w)) \bar{\triangleleft} (\langle v \otimes w \rangle \triangleright g) &= ((\mathbf{f} \times \mathbf{g})(v \otimes w)) \bar{\triangleleft} (\langle v \otimes w \rangle \triangleright g) \\
 &= \left( (\mathbf{g}(w) \bar{\triangleleft} \tau(m_1^L, m_1)^{-1} \otimes \mathbf{f}(v)) \bar{\triangleleft} \tau(m_1, m_2) \right) \bar{\triangleleft} (\langle v \otimes w \rangle \triangleright g) \\
 &= (\mathbf{g}(w) \bar{\triangleleft} \tau(m_1^L, m_1)^{-1} \otimes \mathbf{f}(v)) \bar{\triangleleft} \tau(m_1, m_2) ((\langle v \rangle \cdot \langle w \rangle) \triangleright g) \\
 &= (\mathbf{g}(w) \bar{\triangleleft} \tau(m_1^L, m_1)^{-1} \otimes \mathbf{f}(v)) \bar{\triangleleft} \tau(m_1, m_2) ((m_1 \cdot m_2) \triangleright g) \\
 &= (\mathbf{g}(w) \bar{\triangleleft} \tau(m_1^L, m_1)^{-1} \otimes \mathbf{f}(v)) \bar{\triangleleft} (m_1 \triangleright (m_2 \triangleright g)) \\
 &\quad \tau(m_1 \triangleleft (m_2 \triangleright g), m_2 \triangleleft g) \\
 &= \left( (\mathbf{g}(w)) \bar{\triangleleft} \tau(m_1^L, m_1)^{-1} (m_2 \triangleright g) \otimes \mathbf{f}(v) \bar{\triangleleft} (m_1 \triangleright (m_2 \triangleright g)) \right) \\
 &\quad \bar{\triangleleft} \tau(m_1 \triangleleft (m_2 \triangleright g), m_2 \triangleleft g),
 \end{aligned}$$

which completes the proof where we have used the fact

$$\begin{aligned}
 \tau(m_1^L, m_1)^{-1} (m_2 \triangleright g) &= (m_2 \triangleright g) \tau(m_1^L \triangleleft (m_1 \triangleright (m_2 \triangleright g)), m_1 \triangleleft (m_2 \triangleright g))^{-1} \\
 &= (m_2 \triangleright g) \tau((m_1 \triangleleft (m_2 \triangleright g))^L, m_1 \triangleleft (m_2 \triangleright g))^{-1}.
 \end{aligned}$$

It is noted from the above result that type  $\bar{\mathcal{C}}$  morphisms obey an odd order reversing tensor product rule.

In the next theorem we show that the type  $\bar{\mathcal{C}}$  morphisms satisfy the following property with the braiding map and its inverse (Fig. 2):

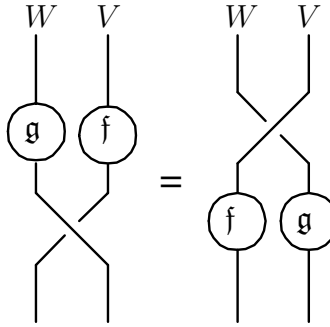

Fig. 2.

**Theorem 4**

Let  $\mathfrak{f} : V \rightarrow \widehat{V}$  and  $\mathfrak{g} : W \rightarrow \widehat{W}$  be type  $\bar{\mathcal{C}}$  morphisms. Then for all  $(w \otimes v) \in W \otimes V$  the following equality is satisfied

$$(\Psi \circ (\mathfrak{g} \times \mathfrak{f}))(w \otimes v) = ((\mathfrak{f} \times \mathfrak{g}) \circ \Psi^{-1})(w \otimes v), \quad (8)$$

where  $\mathfrak{f} \times \mathfrak{g} : V \otimes W \rightarrow \widehat{W} \otimes \widehat{V}$  as defined in Theorem 3,  $\Psi$  is the braiding map and  $\Psi^{-1}$  is its inverse.

**Proof**

We use the double construction to have

$$\begin{aligned} (\mathfrak{g} \times \mathfrak{f})(w \otimes v) &= (\mathfrak{f}(v) \hat{\triangleleft} \tau(\langle w \rangle^L, \langle w \rangle)^{-1} \otimes \mathfrak{g}(w)) \hat{\triangleleft} \tau(\langle w \rangle, \langle v \rangle) \\ &= \mathfrak{f}(v) \hat{\triangleleft} \tau(\langle w \rangle^L, \langle w \rangle)^{-1} (\langle w \rangle^L \triangleright \tau(\langle w \rangle, \langle v \rangle)) \\ &\quad \otimes \mathfrak{g}(w) \hat{\triangleleft} \tau(\langle w \rangle, \langle v \rangle). \end{aligned}$$

Now applying the braiding map to the above equation, we get

$$\Psi((\mathfrak{g} \times \mathfrak{f})(w \otimes v)) = w' \hat{\triangleleft} (\langle v' \rangle \triangleleft |w'|)^{-1} \otimes v' \hat{\triangleleft} |w'|, \quad (9)$$

where  $w' = \mathfrak{g}(w) \hat{\triangleleft} \tau(\langle w \rangle, \langle v \rangle)$  and

$$v' = \mathfrak{f}(v) \hat{\triangleleft} \tau(\langle w \rangle^L, \langle w \rangle)^{-1} (\langle w \rangle^L \triangleright \tau(\langle w \rangle, \langle v \rangle)).$$

To simplify equation (9) we calculate

$$|w'| = |\mathfrak{g}(w) \hat{\triangleleft} \tau(\langle w \rangle, \langle v \rangle)| = (\langle w \rangle^L \triangleright \tau(\langle w \rangle, \langle v \rangle))^{-1} |\mathfrak{g}(w)| \tau(\langle w \rangle, \langle v \rangle).$$

We know that

$$\|\mathfrak{g}(w)\| = \|w\|^L = (|w|^{-1} \langle w \rangle)^L = |w| \langle w \rangle^{-1} = |w| \tau(\langle w \rangle^L, \langle w \rangle)^{-1} \langle w \rangle^L,$$

and on the other side  $\|\mathfrak{g}(w)\| = |\mathfrak{g}(w)|^{-1} \langle \mathfrak{g}(w) \rangle$  which implies that

$$|\mathfrak{g}(w)| = \tau(\langle w \rangle^L, \langle w \rangle) |w|^{-1},$$

by the uniqueness of factorization. So for the right hand side of equation (9), we have

$$v' \hat{\triangleleft} |w'| = \mathbf{f}(v) \hat{\triangleleft} \tau(\langle w \rangle^L, \langle w \rangle)^{-1} |g(w)| \tau(\langle w \rangle, \langle v \rangle) = \mathbf{f}(v) \hat{\triangleleft} |w|^{-1} \tau(\langle w \rangle, \langle v \rangle). \quad (10)$$

Also

$$\begin{aligned} \langle v' \rangle \triangleleft |w'| &= \langle v' \hat{\triangleleft} |w'| \rangle = \langle \mathbf{f}(v) \hat{\triangleleft} |w|^{-1} \tau(\langle w \rangle, \langle v \rangle) \rangle \\ &= \langle \mathbf{f}(v) \rangle \triangleleft |w|^{-1} \tau(\langle w \rangle, \langle v \rangle) = \langle v \rangle^L \triangleleft |w|^{-1} \tau(\langle w \rangle, \langle v \rangle). \end{aligned}$$

So

$$w' \hat{\triangleleft} (\langle v' \rangle \triangleleft |w'|)^{-1} = g(w) \hat{\triangleleft} \tau(\langle w \rangle, \langle v \rangle) (\langle v \rangle^L \triangleleft |w|^{-1} \tau(\langle w \rangle, \langle v \rangle))^{-1}. \quad (11)$$

Thus from (10) and (11), equation (9) can be rewritten as

$$\begin{aligned} \Psi((g \times f)(w \otimes v)) &= g(w) \hat{\triangleleft} \tau(\langle w \rangle, \langle v \rangle) (\langle v \rangle^L \triangleleft |w|^{-1} \tau(\langle w \rangle, \langle v \rangle))^{-1} \\ &\quad \otimes \mathbf{f}(v) \hat{\triangleleft} |w|^{-1} \tau(\langle w \rangle, \langle v \rangle). \end{aligned} \quad (12)$$

Next, for the right hand side of equation (8), we have

$$\begin{aligned} ((f \times g) \circ \Psi^{-1})(w \otimes v) &= (f \times g)(\Psi^{-1}(w \otimes v)) \\ &= (f \times g)(v \hat{\triangleleft} |w \hat{\triangleleft} v|^{-1} \otimes w \hat{\triangleleft} v) \\ &= \left( g(w \hat{\triangleleft} v) \hat{\triangleleft} \tau(\langle v \rangle \triangleleft g, \langle v \rangle \triangleleft g)^{-1} \otimes \mathbf{f}(v \hat{\triangleleft} g) \right) \hat{\triangleleft} \tau(\langle v \rangle \triangleleft g, \langle w \hat{\triangleleft} v \rangle) \\ &= g(w \hat{\triangleleft} v) \hat{\triangleleft} \tau(\langle v \rangle \triangleleft g, \langle v \rangle \triangleleft g)^{-1} (\| \mathbf{f}(v \hat{\triangleleft} g) \| \triangleright \tau(\langle v \rangle \triangleleft g, \langle w \hat{\triangleleft} v \rangle)) \\ &\quad \otimes \mathbf{f}(v \hat{\triangleleft} g) \hat{\triangleleft} \tau(\langle v \rangle \triangleleft g, \langle w \hat{\triangleleft} v \rangle) \\ &= g(w) \hat{\triangleleft} (\|w\| \tilde{\triangleleft} v) \tau(\langle v \rangle \triangleleft g, \langle v \rangle \triangleleft g)^{-1} (\langle v \rangle \triangleleft g)^L \triangleright \tau(\langle v \rangle \triangleleft g, \langle w \hat{\triangleleft} v \rangle) \\ &\quad \otimes \mathbf{f}(v) \hat{\triangleleft} (\|v\| \tilde{\triangleleft} g) \tau(\langle v \rangle \triangleleft g, \langle w \hat{\triangleleft} v \rangle), \end{aligned} \quad (13)$$

where  $g = |w \hat{\triangleleft} v|^{-1}$ . To simplify equation (13) we need to make the following calculations:

$$\|v\| \tilde{\triangleleft} g = |v|^{-1} \langle v \rangle \tilde{\triangleleft} g = |v| g g',$$

where  $\|v\|\tilde{\triangleleft}g = g^{-1}|v|^{-1}\langle v\rangle g = g^{-1}|v|^{-1}(\langle v\rangle\triangleright g)(\langle v\rangle\triangleleft g) = g'm'$ . Using the uniqueness of factorization we obtain  $g' = g^{-1}|v|^{-1}(\langle v\rangle\triangleright g)$  and hence  $\|v\|\tilde{\triangleright}g = (\langle v\rangle\triangleright g)$ . Moreover,

$$\begin{aligned} (\langle v\rangle\triangleleft g)\langle w\hat{\triangleleft}v\rangle &= (\langle v\rangle\triangleright g)^{-1}\langle v\rangle g\langle w\hat{\triangleleft}v\rangle = (\langle v\rangle\triangleright g)^{-1}\langle v\rangle|w\hat{\triangleleft}v|^{-1}\langle w\hat{\triangleleft}v\rangle \\ &= (\langle v\rangle\triangleright g)^{-1}\langle v\rangle\|w\hat{\triangleleft}v\| = (\langle v\rangle\triangleright g)^{-1}\langle v\rangle(\|w\|\tilde{\triangleleft}v) \\ &= (\langle v\rangle\triangleright g)^{-1}\langle v\rangle(\langle v\rangle^{-1}\|w\|\langle v\rangle) = (\langle v\rangle\triangleright g)^{-1}|w|^{-1}\langle w\rangle\langle v\rangle \\ &= (\langle v\rangle\triangleright g)^{-1}|w|^{-1}\tau(\langle w\rangle, \langle v\rangle)(\langle w\rangle \cdot \langle v\rangle). \end{aligned}$$

But, on the other hand  $(\langle v\rangle\triangleleft g)\langle w\hat{\triangleleft}v\rangle = \tau(\langle v\rangle\triangleleft g, \langle w\hat{\triangleleft}v\rangle)((\langle v\rangle\triangleleft g) \cdot \langle w\hat{\triangleleft}v\rangle)$ . So, by the uniqueness of factorization, we get

$$\tau(\langle v\rangle\triangleleft g, \langle w\hat{\triangleleft}v\rangle) = (\langle v\rangle\triangleright g)^{-1}|w|^{-1}\tau(\langle w\rangle, \langle v\rangle),$$

and

$$((\langle v\rangle\triangleleft g) \cdot \langle w\hat{\triangleleft}v\rangle) = (\langle w\rangle \cdot \langle v\rangle). \quad (14)$$

Thus, the right part of the tensor of (13) becomes

$$\mathfrak{f}(v)\hat{\triangleleft}(\|v\|\tilde{\triangleright}g)\tau(\langle v\rangle\triangleleft g, \langle w\hat{\triangleleft}v\rangle) = \mathfrak{f}(v)\hat{\triangleleft}|w|^{-1}\tau(\langle w\rangle, \langle v\rangle), \quad (15)$$

which is the same as the right part of the tensor of (12). Now, in order to simplify the left part of the tensor of equation (13), we have

$$\begin{aligned} \|w\|\tilde{\triangleleft}v &= \langle v\rangle^{-1}|w|^{-1}\langle w\rangle\langle v\rangle \\ &= \tau(\langle v\rangle^L, \langle v\rangle)^{-1}\langle v\rangle^L|w|^{-1}\tau(\langle w\rangle, \langle v\rangle)(\langle w\rangle \cdot \langle v\rangle) \\ &= \tau(\langle v\rangle^L, \langle v\rangle)^{-1}(\langle v\rangle^L\triangleright|w|^{-1}\tau(\langle w\rangle, \langle v\rangle)) \\ &\quad (\langle v\rangle^L\triangleleft|w|^{-1}\tau(\langle w\rangle, \langle v\rangle))(\langle w\rangle \cdot \langle v\rangle) \\ &= \tau(\langle v\rangle^L, \langle v\rangle)^{-1}(\langle v\rangle^L\triangleright|w|^{-1}\tau(\langle w\rangle, \langle v\rangle)) \\ &\quad \tau((\langle v\rangle^L\triangleleft|w|^{-1}\tau(\langle w\rangle, \langle v\rangle)), (\langle w\rangle \cdot \langle v\rangle)) \\ &\quad (\langle v\rangle^L\triangleleft|w|^{-1}\tau(\langle w\rangle, \langle v\rangle)) \cdot (\langle w\rangle \cdot \langle v\rangle) = g''m''. \end{aligned}$$

So

$$\begin{aligned} \|w\|\tilde{\triangleright}v &= |w|^{-1}\langle w\rangle\tilde{\triangleright}v = |w|\langle v\rangle g'' \\ &= |w|\langle v\rangle\tau(\langle v\rangle^L, \langle v\rangle)^{-1}(\langle v\rangle^L\triangleright|w|^{-1}\tau(\langle w\rangle, \langle v\rangle)) \\ &\quad \tau(\langle v\rangle^L\triangleleft|w|^{-1}\tau(\langle w\rangle, \langle v\rangle), \langle w\rangle \cdot \langle v\rangle). \end{aligned}$$

Also

$$\begin{aligned}
& (\langle v \rangle \triangleleft g)^L \triangleright \tau(\langle v \rangle \triangleleft g, \langle w \hat{\triangleleft} \langle v \rangle \rangle) \\
&= \tau((\langle v \rangle \triangleleft g)^L, \langle v \rangle \triangleleft g) \tau\left((\langle v \rangle \triangleleft g)^L \triangleleft \tau(\langle v \rangle \triangleleft g, \langle w \hat{\triangleleft} \langle v \rangle \rangle), (\langle v \rangle \triangleleft g) \cdot \langle w \hat{\triangleleft} \langle v \rangle \rangle\right)^{-1} \\
&= \tau((\langle v \rangle \triangleleft g)^L, \langle v \rangle \triangleleft g) \\
&\quad \tau\left((\langle v \rangle \triangleleft (\langle v \rangle \triangleright g)) \triangleleft (\langle v \rangle \triangleright g)^{-1} |w|^{-1} \tau(\langle w \rangle, \langle v \rangle), \langle w \rangle \cdot \langle v \rangle\right)^{-1} \\
&= \tau((\langle v \rangle \triangleleft g)^L, \langle v \rangle \triangleleft g) \tau\left(\langle v \rangle \triangleleft |w|^{-1} \tau(\langle w \rangle, \langle v \rangle), \langle w \rangle \cdot \langle v \rangle\right)^{-1}
\end{aligned}$$

So, the left part of the tensor of (13) can be rewritten as

$$\begin{aligned}
& \mathfrak{g}(w) \hat{\triangleleft} |w| \langle v \rangle \tau(\langle v \rangle^L, \langle v \rangle)^{-1} (\langle v \rangle^L \triangleright |w|^{-1} \tau(\langle w \rangle, \langle v \rangle)) \\
&= \mathfrak{g}(w) \hat{\triangleleft} |w| (\langle v \rangle^L)^{-1} (\langle v \rangle^L \triangleright |w|^{-1} \tau(\langle w \rangle, \langle v \rangle)) \\
&= \mathfrak{g}(w) \hat{\triangleleft} \tau(\langle w \rangle, \langle v \rangle) (\langle v \rangle^L \triangleleft |w|^{-1} \tau(\langle w \rangle, \langle v \rangle))^{-1}.
\end{aligned}$$

Hence (13) can be rewritten as

$$\begin{aligned}
((\mathfrak{f} \times \mathfrak{g}) \circ \Psi^{-1})(w \otimes v) &= \mathfrak{g}(w) \hat{\triangleleft} \tau(\langle w \rangle, \langle v \rangle) (\langle v \rangle^L \triangleleft |w|^{-1} \tau(\langle w \rangle, \langle v \rangle))^{-1} \\
&\quad \otimes \mathfrak{f}(v) \hat{\triangleleft} |w|^{-1} \tau(\langle w \rangle, \langle v \rangle).
\end{aligned}$$

which completes the proof.

It is obvious to show that the composition of two type  $\bar{\mathcal{C}}$  morphisms is a type  $\mathcal{C}$  morphism and also that the composition of a type  $\mathcal{C}$  morphism and a type  $\bar{\mathcal{C}}$  morphism is a type  $\bar{\mathcal{C}}$  morphism.

### Example 5

The map  $\star : A \rightarrow A$  which is defined by

$$\star(\delta_m \otimes g) = \delta_{m \triangleleft g \tau(m_1^L, m_1)^{-1}} \otimes \tau(m_1^L, m_1) g^{-1},$$

where  $(\delta_m \otimes g) \in A$  and  $m_1 = \langle \delta_m \otimes g \rangle$ , is a type  $\bar{\mathcal{C}}$  morphism. Moreover, the map  $\star : A \rightarrow A$  satisfies

$$\star(\star(\delta_m \otimes g) \bar{\triangleleft} \tau(m_1, m_1^L)) = \text{id}_A.$$

This map looks like the  $\star$  operation defined on  $A$  by  $(\delta_m \otimes g)^* = \delta_{m \triangleleft g} \otimes g^{-1}$  in the case where  $M$  is a subgroup of  $X$  (see [2&6]).

The effect of a type  $\bar{\mathcal{C}}$  morphism on the action of the algebra  $A$  is given by the following equality:

$$\mathfrak{f}(v\bar{\triangleleft}(\delta_m \otimes g)) = \mathfrak{f}(v)\bar{\triangleleft}F(\delta_m \otimes g),$$

where the map  $F : A \rightarrow A$  is defined by  $F(\delta_m \otimes g) = \delta_{mL} \otimes (m\triangleright g)$ .

In the rest of this paper, we discuss the connection between type  $\mathcal{C}$  and type  $\bar{\mathcal{C}}$  morphisms assuming that there is a right inverse in  $M$  and that there is a conjugate  $\bar{x}$  for all  $x$  in the field  $k$ .

**Definition 6**

A functor  $\mathfrak{B} : \mathcal{C} \rightarrow \mathcal{C}$  is defined by  $\mathfrak{B}(V) = \bar{V}$ , for  $V \in \mathcal{C}$ , where  $\bar{V} = V$  as a set with the usual addition and for  $\bar{v} \in \bar{V}$ ,  $\bar{v}x = v\bar{x}$  (conjugate scalar multiplication). In addition, the grade of  $\bar{v} \in \bar{V}$  is given by  $\langle \bar{v} \rangle = \langle v \rangle^R$  and the  $G$ -action on  $\bar{V}$  is given by

$$\bar{v} \bar{\triangleleft} g = v \bar{\triangleleft} (\langle \bar{v} \rangle \triangleright g) = v \bar{\triangleleft} (\langle v \rangle^R \triangleright g).$$

Moreover, for a morphism  $\mathfrak{f}$  in the category,  $\bar{\mathfrak{f}}(v) = \mathfrak{f}(v)$  as a function between sets.

For the  $M$ -grading and the  $G$ -action, we have

**Proposition 7**

The  $M$ -grading and the  $G$ -action given in definition 6 are consistent.

**Proof**

For  $v \in V$  and  $\bar{v} \in \bar{V}$ , we have

$$\langle \bar{v} \bar{\triangleleft} g \rangle = \langle v \bar{\triangleleft} (\langle v \rangle^R \triangleright g) \rangle = \langle v \rangle \triangleleft (\langle v \rangle^R \triangleright g) = \langle v \rangle^R \triangleleft g = \langle \bar{v} \rangle \triangleleft g,$$

where the third equality is due to the fact that  $(m_1 \cdot m_2) \triangleleft g = (m_1 \triangleleft (m_2 \triangleright g)) \cdot (m_2 \triangleleft g)$  for  $m_1, m_2 \in M$  and  $g \in G$ .

**Theorem 8**

There is a natural transformation  $F$  between the  $\mathfrak{B} : \mathcal{C} \rightarrow \mathcal{C}$  functor and the identity functor  $I_{\mathcal{C}} : \mathcal{C} \rightarrow \mathcal{C}$ , defined by

$$F_V(\bar{v}) = v \bar{\triangleleft} \tau(\langle \bar{v} \rangle^L, \langle \bar{v} \rangle),$$

that is the following diagram commutes (Fig. 3):

$$\begin{array}{ccc} \bar{\bar{V}} & \xrightarrow{F_V} & V \\ \downarrow \bar{\bar{f}} & & \downarrow \bar{f} \\ \bar{\bar{W}} & \xrightarrow{F_W} & W \end{array}$$

**Fig. 3.**

**Proof**

We use  $v, \bar{v}, \bar{\bar{v}}$  to distinguish  $v \in V$  as an element of  $V, \bar{V}, \bar{\bar{V}}$  respectively. To show that  $F_V : \bar{\bar{V}} \rightarrow V$  is a morphism in the category, we need to check the  $M$ -grade and the  $G$ -action. First we check the  $M$ -grade

$$\langle F_V(\bar{\bar{v}}) \rangle = \langle v \bar{\triangleleft} \tau(\langle \bar{\bar{v}} \rangle^L, \langle \bar{\bar{v}} \rangle) \rangle = \langle v \triangleleft \tau(\langle v \rangle^R, \langle v \rangle^{RR}) \rangle = \langle v \rangle^{RR} = \langle \bar{\bar{v}} \rangle,$$

as required. Now to check the  $G$ -action, we need to calculate

$$\begin{aligned} \bar{\bar{v}} \bar{\triangleleft} g &= \bar{\bar{v}} \bar{\triangleleft} (\langle \bar{\bar{v}} \rangle^R \triangleright g) = \bar{\bar{v}} \bar{\triangleleft} (\langle v \rangle^{RR} \triangleright g) = v \bar{\triangleleft} (\langle v \rangle^R \triangleright (\langle v \rangle^{RR} \triangleright g)) \\ &= v \bar{\triangleleft} \tau(\langle v \rangle^R, \langle v \rangle^{RR}) g \tau(\langle v \rangle^R \triangleleft (\langle v \rangle^{RR} \triangleright g), (\langle v \rangle^{RR} \triangleleft g))^{-1}, \end{aligned}$$

where we have used  $m_1 \triangleright (m_2 \triangleright g) = \tau(m_1, m_2)((m_1 \cdot m_2) \triangleright g) \tau(m_1 \triangleleft (m_2 \triangleright g), m_2 \triangleleft g)^{-1}$  for  $m_1, m_2 \in M$  and  $g \in G$ . If we put  $\bar{\bar{v}} \bar{\triangleleft} g = \bar{\bar{w}}$ , then

$$F_V(\bar{\bar{v}} \bar{\triangleleft} g) = F_V(\bar{\bar{w}}) = w \bar{\triangleleft} \tau(\langle \bar{\bar{w}} \rangle^L, \langle \bar{\bar{w}} \rangle) = w \bar{\triangleleft} \tau(\langle w \rangle^R, \langle w \rangle^{RR}).$$

So

$$\begin{aligned}\langle w \rangle &= \langle v \rangle \triangleleft \tau(\langle v \rangle^R, \langle v \rangle^{RR}) g \tau(\langle v \rangle^R \triangleleft (\langle v \rangle^{RR} \triangleright g), (\langle v \rangle^{RR} \triangleleft g))^{-1} \\ &= \langle v \rangle^{RR} \triangleleft g \tau(\langle v \rangle^R \triangleleft (\langle v \rangle^{RR} \triangleright g), (\langle v \rangle^{RR} \triangleleft g))^{-1}.\end{aligned}$$

Then there is  $g_1 \in G$  such that

$$\begin{aligned}g_1 \langle w \rangle &= \langle v \rangle^{RR} g \tau(\langle v \rangle^R \triangleleft (\langle v \rangle^{RR} \triangleright g), (\langle v \rangle^{RR} \triangleleft g))^{-1} \\ &= (\langle v \rangle^{RR} \triangleright g)(\langle v \rangle^{RR} \triangleleft g) \tau(\langle v \rangle^R \triangleleft (\langle v \rangle^{RR} \triangleright g), (\langle v \rangle^{RR} \triangleleft g))^{-1} \\ &= (\langle v \rangle^{RR} \triangleright g)(\langle v \rangle^R \triangleleft (\langle v \rangle^{RR} \triangleright g))^{-1},\end{aligned}$$

which implies that  $\langle w \rangle = (\langle v \rangle^R \triangleleft (\langle v \rangle^{RR} \triangleright g))^L$ . Thus

$$\begin{aligned}F_V(\bar{w}) &= F_V(\bar{v} \triangleleft g) = w \triangleleft \tau(\langle v \rangle^R \triangleleft (\langle v \rangle^{RR} \triangleright g), \langle v \rangle^{RR} \triangleleft g) \\ &= v \triangleleft \tau(\langle v \rangle^R, \langle v \rangle^{RR}) g = (v \triangleleft \tau(\langle \bar{v} \rangle^L, \langle \bar{v} \rangle)) \triangleleft g \\ &= F_V(\bar{v}) \triangleleft g,\end{aligned}$$

as required.

### **Remark 9**

A type  $\bar{\mathcal{C}}$  morphism  $\mathfrak{f} : V \rightarrow W$  can be viewed as a type  $\mathcal{C}$  morphism  $\mathfrak{f} : V \rightarrow \bar{W}$  (same as a function on sets). Indeed, as for the  $M$ -grade we have

$$\langle \overline{\mathfrak{f}(v)} \rangle = \langle \mathfrak{f}(v) \rangle^R = \langle v \rangle.$$

And for the  $G$ -action we know  $\mathfrak{f}(v \triangleleft g) = \mathfrak{f}(v) \triangleleft (\langle v \rangle \triangleright g)$ , but we also have

$$\overline{\mathfrak{f}(v)} \triangleleft g = \mathfrak{f}(v) \triangleleft (\langle \mathfrak{f}(v) \rangle^R \triangleright g) = \mathfrak{f}(v) \triangleleft (\langle v \rangle \triangleright g),$$

as required where  $v \in V$ .

### **Acknowledgment**

I would like to thank Prof. E.J. Beggs for his comments and many fruitful discussions. I also thank the referees for a substantial improvement in the presentation of this paper.



## References

- [1] **Majid, S.**, Physics for algebraists: Non-commutative and non-cocommutative Hopf algebras by bicrossproduct construction, *J. Algebra*, **130**: 17 - 64 (1990).
- [2] **Beggs, E. J., Gould, J. D. and Majid, S.**, Finite group factorizations and braiding, *J. Algebra*, **181** (1): 112 - 151 (1996).
- [3] **Beggs, E. J. and Majid, S.**, Quasitriangular and differential structures on bicrossproduct Hopf algebras, *J. Algebra*, **219** (2): 682 - 727 (1999).
- [4] **Beggs, E. J.**, Making non-trivially associated tensor categories from left coset representatives, *Journal of Pure and Applied Algebra*, **177**: 5 - 41 (2003).
- [5] **Al-Shomrani, M. M. and Beggs, E. J.**, Making nontrivially associated modular categories from finite groups, *International Journal of Mathematics and Mathematical Science*, **42** : 2231-2264 (2004).
- [6] **Al-Shomrani, M. M.**, Braided Hopf Algebras and Non-Trivially Associated Tensor Categories, *Ph.D. Thesis* , University of Wales, Swansea, (2003).
- [7] **Al-Shomrani, M. M.**, Algebras and their dual in rigid tensor categories, *Int. Math. Forum*, **1** (9 -12): 525 - 550 (2006).
- [8] **Milnor, J. and Moore, J. ,** On the structure of Hopf algebras, *Ann. of Math.*, **81** (2): 211-264 (1965).
- [9] **Majid, S.**, *Foundations of Quantum Group Theory*, Cambridge: Cambridge University Press, (1995).
- [10] **Kassel, C.**, *Quantum Groups*, Graduate Texts in Mathematics, New York: Springer-Verlag, 155:(1995).

## المصنفات الضربية غير بدهية التجميع الموسعة

محمد موسى الشمrani

قسم الرياضيات، كلية العلوم، جامعة الملك عبدالعزيز

جدة - المملكة العربية السعودية

المستخلص. في هذا البحث، تم إنشاء مصنف جديد بإضافة نواقل جديدة لمصنف ضربى غير بدهى التجميع. ثم تمت دراسة خصائص هذه النواقل مع توضيحها بمثال. أخيرا، تم تحديد طبيعة العلاقة بين هذا المصنف الناشئ والمصنف الأصل.