

## ACI Code Torsion Equations Modified for Rectangular Concrete Beams with an Opening

ALI A. AKHTARUZZAMAN

*Civil Engineering Department, Faculty of Engineering,  
King Abdulaziz University, Jeddah, Saudi Arabia.*

**ABSTRACT.** The ACI Code torsion equations for concrete beams of solid cross-section have been modified to predict the torsional strength of rectangular beams with a transverse opening. The equations have also been adapted to include the effect of torsion-bending interaction at low T/M ratios. A comparison with available test results of fifty-one beams subjected to different combinations of torsion, bending and shear shows excellent agreement between the predicted values and the experimental results at all ranges of T/M ratios. Results of torsion tests on twenty-three plain concrete and partially reinforced concrete beams with a rectangular opening are also presented.

### Introduction

Beams in multistoried buildings are often provided with transverse openings in the webs. Such openings may significantly reduce their torsional strength. The ACI Code<sup>[1]</sup> equations which are based on Hsu's<sup>[2]</sup> research on reinforced concrete beams of solid section, do not have any provisions for designing such beams. Some research workers<sup>[3-7]</sup> have investigated torsional strength of beams with a transverse opening of different profiles. But the equations developed by them are rather complex. It may, however, be possible to modify the existing ACI Code equations suitably to predict the torsional strength of a rectangular beam section with a transverse opening.

### The ACI Code Equations and Proposed Modifications

According to the ACI Code<sup>[1]</sup>, the nominal torsional strength  $T_n$ , of a reinforced concrete beam of solid cross-section is obtained as

$$T_n = T_c + T_s \quad (1)$$

where  $T_c$  is the nominal torsional strength provided by concrete and  $T_s$  is the nominal torsional strength provided by torsional reinforcement. Similarly, the nominal torsional strength of a beam containing an opening  $T_{nh}$ , can also be written as

$$T_{nh} = T_{ch} + T_{sh} \quad (2)$$

where  $T_{ch}$  and  $T_{sh}$  are the nominal torsional strengths provided by concrete section containing the opening and by the torsional reinforcement in the hole section, respectively.

### a. Rectangular Beams Subjected to Torsion Only

#### i. Solid beams

For a beam of solid cross-section, the ACI Code equations for  $T_c$  and  $T_s$  are

$$T_c = 0.8 \sqrt{f'_c} b^2 h \quad (3)$$

and

$$T_s = \frac{A_t \alpha_t x_1 y_1 f_y}{s} \quad (4)$$

where  $A_t$  is the area of one leg of a vertical stirrup,  $b$  and  $h$  are the width and depth of the beam section,  $f'_c$  is the compressive strength of concrete,  $f_y$  is the yield strength of steel,  $s$  is the stirrup spacing,  $x_1$  and  $y_1$  are the shorter and longer center-to-center dimensions of the stirrups, and  $\alpha_t$  is a coefficient as a function of  $x_1$  and  $y_1$ .

According to Winter and Nilson<sup>[8]</sup>,  $T_c$  in Eq. 3 represents 40 percent of the torsional strength of a plain concrete beam  $T_{pc}$ , given by

$$T_{pc} = 2 \sqrt{f'_c} b^2 h \quad (5)$$

Equation 5 is similar to Hsu's<sup>[9]</sup> equation for torsional strength of a plain concrete beam, *i.e.*,

$$T_{pc} = \frac{0.85}{3} b^2 h f_r \quad (6)$$

where  $f_r$  is the modulus of rupture of concrete.

Equation 4 can be written as

$$T_s = n A_t \alpha_t x_1 f_y \quad (7)$$

where  $n (= y_1/s)$  represents the number of vertical legs of stirrups intersected by a 45° plane on the tension side of the beam as shown in Fig. 1. The coefficient  $\alpha_t$  depends on the ratio of beam cross-sectional dimensions and is taken<sup>[1]</sup> as

$$\alpha_t = 0.66 + 0.33 \frac{y_1}{x_1} \leq 1.50 \quad (8)$$

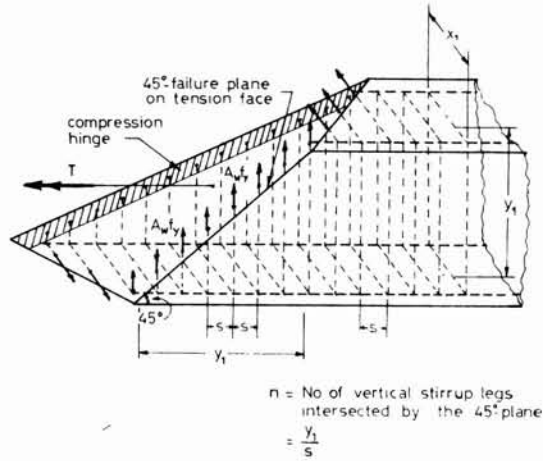

FIG. 1. Failure surface of a rectangular beam under torsion.

### ii) Beams with an opening

According to Mansur and Hasnat<sup>[3]</sup>, the torsional strength  $T_{pch}$ , of a plain concrete beam with a symmetrically located circular opening is given by

$$T_{pch} = \frac{0.85}{6} b^2 h \left( \sec \theta - \frac{d_0}{h} \right) \operatorname{cosec} \theta f_r \quad (9)$$

where  $d_0$  is the diameter of the opening. The failure plane inclination with the vertical plane  $\theta$  can be obtained by differentiating Eq. 9 with respect to  $\theta$ , and equating to zero. This results in

$$\sec^3 \theta - 2 \sec \theta + \frac{d_0}{h} = 0 \quad (10)$$

Equation 10 shows that the failure plane inclination  $\theta$  depends on  $d_0/h$ . It can, however, be observed in Table 1 that for  $d_0/h$  up to 0.5,  $\theta$  does not vary significantly with  $d_0/h$  and for all practical purposes, it can be reasonably taken as  $45^\circ$ . This reduces Eq. 9 to

$$T_{pch} = \frac{0.85}{3} b^2 h \left( 1 - 0.707 \frac{d_0}{h} \right) f_r \quad (11)$$

Table 1 further shows that for  $d_0/h \leq 0.5$ , the torsional strength of plain concrete beams with a circular opening as given by Eq. 11 is quite close to that given by Eq. 9. It is, thus, deemed permissible to use Eq. 11 in lieu of Eq. 9 for beams with a circular opening for  $d_0/h \leq 0.5$ .

Mansur and Hasnat<sup>[3]</sup> also suggested that for plain concrete beams with a rectangular opening with its longer side parallel to the longitudinal axis of the beam, the torsional strength is given by

$$T_{pch} = \frac{0.85}{3} b^2 h \left( 1 - \frac{d_0}{h} \right) f_r \quad (12)$$

TABLE 1. Comparison between Eqs. 9 and 11

Ratio $\frac{d_0}{h}$	Failure crack inclination $\theta$ (degree)	Theoretical torsional strength using		$\frac{\text{Col. (4)}}{\text{Col. (3)}}$
		Eq. 9 ( $\times b^2 h f_r$ )	Eq. 11 ( $\times b^2 h f_r$ )	
0.0	45.0	0.2833	0.2833	1.000
0.1	43.9	0.2631	0.2633	1.001
0.2	42.7	0.2425	0.2433	1.003
0.3	41.4	0.2213	0.2232	1.008
0.4	39.8	0.1995	0.2032	1.018
0.5	37.9	0.1170	0.1832	1.035
0.6	35.6	0.1533	0.1631	1.064

where  $d_0$  is taken to represent the opening depth and  $d_0 \leq b_0$ , the opening length. No experimental evidence supporting the validity of Eq. 12 is, however, available.

Basically Eq. 11 and 12 are a modified form of Eq. 6 incorporating the factor  $(1 - \lambda d_0/h)$  to take into account the reduction in torsional strength due to the transverse opening where  $\lambda = \cos 45^\circ$  for a circular opening and  $\lambda = 1.0$  for a rectangular opening. Likewise, Eq. 5 can also be modified to obtain the torsional strength of plain concrete beams containing an opening  $T_{pch}$ , as

$$T_{pch} = 2 \sqrt{f'_c} b^2 h \left( 1 - \lambda \frac{d_0}{h} \right) \quad (13)$$

Assuming that the nominal torsional strength  $T_{ch}$ , provided by the concrete section in a reinforced concrete beam with an opening as 40 percent of  $T_{pch}$ ,

$$T_{ch} = 0.8 \sqrt{f'_c} b^2 h \left( 1 - \lambda \frac{d_0}{h} \right) \quad (14)$$

Following Eq. 7, the torsional strength provided by the torsional reinforcement around the hole section  $T_{sh}$ , can be written as

$$T_{sh} = n_h A_t \alpha_t x_1 f_y \quad (15)$$

where  $n_h$  represents the number of vertical stirrups intersected by a failure plane passing through the hole section on the tension side. For beams with a rectangular opening, Hasnat and Akhtaruzzaman<sup>[6]</sup> observed that the failure plane passed through a corner of the opening with its inclination nearly constant at around  $45^\circ$ . Thus, as shown in Fig. 2a, for a rectangular opening with  $d_0 \leq b_0$ ,

$$n_h = \left( 1 - \frac{d_0}{y_1} \right) \frac{y_1}{s} \tag{16}$$

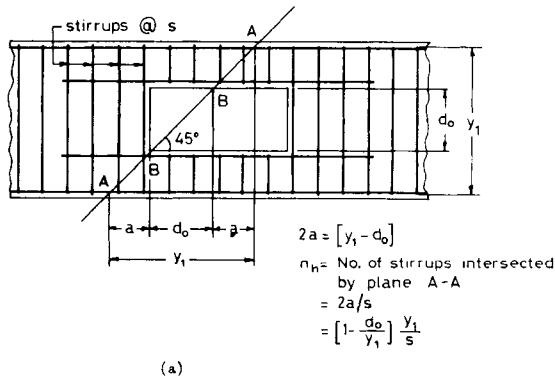
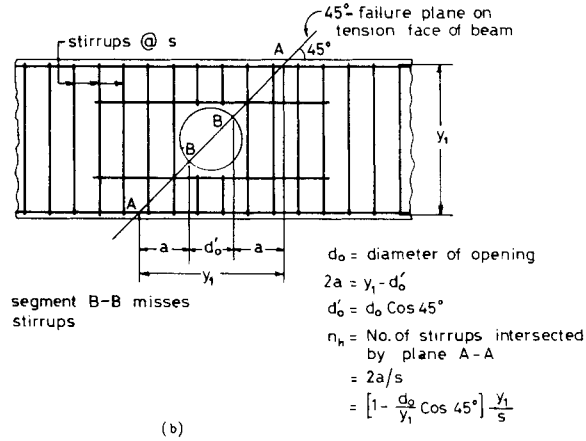

FIG. 2. Failure plane on the tension side of a beam with a transverse opening.

For beams with a circular opening, the failure plane may have a variable inclination depending on  $d_0/h$ . For practical purposes, however, the failure plane inclination may be taken to be  $45^\circ$  as in the case of plain concrete beams. Then, with the failure plane assumed to pass through the centre of the opening, as shown in Fig. 2b,

$$n_h = \left( 1 - \frac{d_0}{y_1} \cos 45^\circ \right) \frac{y_1}{s} \tag{17}$$

Substituting the values from Eq. 14 and 15, Eq. 2 can be written as

$$T_{nh} = 0.8 \sqrt{f'_c} b^2 h \left( 1 - \lambda \frac{d_0}{h} \right) + A_t \alpha_t x_1 f_y \left( 1 - \lambda \frac{d_0}{y_1} \right) \frac{y_1}{s} \quad (18)$$

where  $\lambda = \cos 45^\circ$  for a circular opening and  $\lambda = 1.0$  for a rectangular opening.

As a special case, beams with reinforced throat section, *i.e.*, the section above and below the opening, may also be considered. Experimental results<sup>[3]</sup> show that for beams with horizontal and vertical steel only around a small circular opening, the failure plane can have an inclination steeper than  $45^\circ$  and it can pass through an unreinforced throat section as shown in Fig. 3. For such beams, the term  $n_h$  in Eq. 15 should be taken as the minimum number of vertical stirrups such a crack will pass through on one side only of the opening, both circular and rectangular (with  $d_0 \leq b_0$ ).

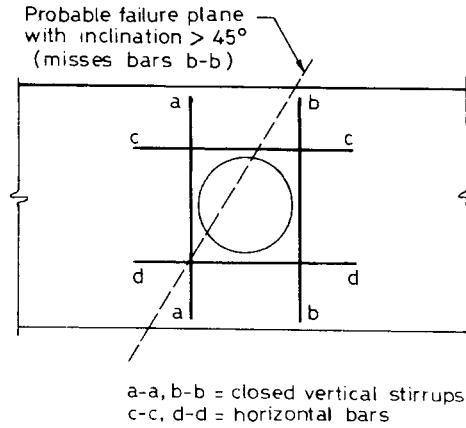

FIG. 3. Failure plane avoiding steel reinforcement.

Beams containing inclined bars only around a circular opening as shown in Fig. 4 may also be considered as another special case. Since the inclined bars extend inside the throat section, the number of such bars intersected by any failure plane passing through the opening will not be less than  $n_d$  the number intersected by a plane through a diameter. Thus,  $T_{dsh}$ , the torsional strength due to the inclined bars only may be obtained as

$$T_{dsh} = n_d A_d f_y x_1 \alpha_t (\sin \theta' + \cos \theta') \quad (19)$$

where  $A_d$  is the area of an inclined bar around the opening,  $\theta'$  represents the inclination of the bars and the term  $(\sin \theta' + \cos \theta')$  has the same connotation as in the case of shear strength due to inclined stirrups.

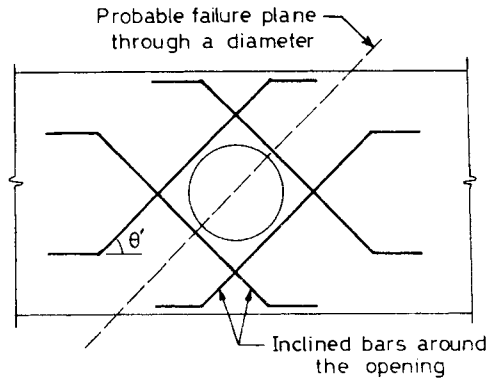

FIG. 4. Failure plane passing through a diameter with inclined bars around the opening.

**b. Rectangular Beams Subjected to Torsion and Bending**

The ACI code does not have any special provision for simultaneous action of torsion and bending. It assumes that there is no interaction between them. Test results<sup>[4,5,10]</sup> on beams of solid cross-section as well as containing an opening, however, show that the torsional strength is adversely affected in the low range of  $T/M$  ratios, especially when beams suffer Mode 1 failure according to the so-called skew bending model<sup>[11]</sup>. Thus, the torsional strength as given by the ACI code needs to be modified for low  $T/M$  ratios. This can be done on the basis of experimental results.

**c. Rectangular Beams Subjected to Torsion, Bending and Shear**

**i. Solid beams**

For rectangular beams of solid cross-section, the ACI code<sup>[1]</sup> gives  $T_c$  as

$$\hat{T}_c = \frac{0.8 \sqrt{f'_c} b^2 h}{\sqrt{1 + \left[ \frac{0.4 V_u}{C_t T_u} \right]^2}} \tag{20}$$

where  $T_u$  and  $V_u$  are the factored torsional moment and shear force at the section respectively, and  $C_t$  is a factor relating shear and torsional stress properties.

Since stirrups are used to resist both flexural shear force and torsional moment, the torsional strength provided by stirrups  $T_s$ , can be obtained by using the principle of superposition. According to the ACI code<sup>[1]</sup>, the nominal shear strength  $V_n$ , of a reinforced concrete beam is given by

$$V_n = V_c + V_s \tag{21}$$

where  $V_c$  and  $V_s$  are the shear resistance contributed by concrete and web reinforcements, respectively. The former is given as

$$V_c = \frac{2 \sqrt{f'_c} b d}{\sqrt{1 + \left[ 2.5 C_t \frac{T_u}{V_u} \right]^2}} \quad (22)$$

Assuming that  $V_s$  alone causes the stirrups to be stressed to  $f_{sv}$ ,

$$V_s = \frac{A_v f_{sv} d}{s} = V_n - V_c \quad (23)$$

where  $A_v$  is the area of both legs of a stirrup and  $d$  is the effective depth of the section. Hence,

$$f_{sv} = \frac{(V_n - V_c) s}{A_v d} \quad (24)$$

The torsional strength provided by the stirrups can then be obtained as

$$T_s = \frac{A_t \alpha_t x_1 y_1}{s} (f_y - f_{sv}) \quad (25)$$

Substituting the values from Eq. 20 and 25, Eq. 1 can be written as

$$T_n = \frac{0.8 \sqrt{f'_c} b^2 h}{\sqrt{1 + \left[ \frac{0.4 V_u}{C_t T_u} \right]^2}} + \frac{A_t \alpha_t x_1 y_1}{s} (f_y - f_{sv}) \quad (26)$$

#### ii. Beams with an opening

It may be reasonably assumed that Eq. 20 can be modified by introducing the factor  $(1 - \lambda d_0/h)$  to obtain  $T_{ch}$  as

$$T_{ch} = \frac{0.8 \sqrt{f'_c} b^2 h}{\sqrt{1 + \left[ \frac{0.4 V_u}{C_t T_u} \right]^2}} (1 - \lambda \frac{d_0}{h}) \quad (27)$$

As in the case of beams of solid section, the torsional strength provided by the stirrups can be computed by using superposition. The nominal shear strength  $V_{nh}$ , can be obtained as

$$V_{nh} = V_{ch} + V_{sh} \quad (28)$$

where  $V_{ch}$  and  $V_{sh}$  are the shear resistance contributed by concrete and web reinforcements, respectively, at the opening section.

Equation 22 may be modified by introducing the factor  $(1 - d_0/d)$  to give  $V_{ch}$  as



$$V_{ch} = \frac{2 \sqrt{f'_c} \, b d}{\sqrt{1 + \left[ 2.5 C_t \frac{T_u}{V_u} \right]^2}} \left( 1 - \frac{d_0}{d} \right) \quad (29)$$

The term  $(1 - d_0/d)$  is introduced to take into account the loss of shear resistance due to the transverse opening.

The shear resistance due to web reinforcements may be computed as

$$V_{sh} = \frac{V_v f_{svh} d}{s} \left( 1 - \frac{d_0}{d} \right) \quad (30)$$

where  $f_{svh}$  represents the stress induced in the web reinforcements (long stirrups) due to shear force alone and the term  $(1 - d_0/d)$  has the same connotation as before.

Thus, from Eq. 28, 29 and 30,

$$f_{svh} = (V_{nh} - V_{ch}) \frac{s}{A_v d \left( 1 - \frac{d_0}{d} \right)} \quad (31)$$

The torsional resistance  $T_{sh}$  provided by the stirrups at the opening section can be reasonably taken as

$$T_{sh} = \frac{A_t \alpha_t x_1 y_1}{s} (f_y - f_{svh}) \left( 1 - \lambda \frac{d_0}{y_1} \right) \quad (32)$$

The term  $(1 - \lambda d_0/y_1)$  has the same connotation as in Eq. 18.

Substituting the values from Eqs. 27 and 32, Eq. 2 can be written as

$$T_{nh} = \frac{0.8 \sqrt{f'_c} \, b^2 h}{\sqrt{1 + \left[ \frac{0.4 V_u}{C_t T_u} \right]^2}} \left( 1 - \lambda \frac{d_0}{h} \right) + \frac{A_t \alpha_t x_1 y_1}{s} (f_y - f_{svh}) \left( 1 - \lambda \frac{d_0}{y_1} \right) \quad (33)$$

The equations presented are applicable to beams with a circular or a rectangular opening with  $d_0 \leq b_0$ . For beams having a rectangular opening with  $d_0 > b_0$ , the equations may also be applied by replacing  $d_0$  by  $b_0$ .

### Experimental Program

As no experimental evidence was available supporting the validity of Mansur and Hasnat's equation<sup>[3]</sup> for beams with a rectangular opening, an experimental program was planned primarily to verify Eq. 12. Twenty-three concrete beams of 9ft 2in.

(2.79m) length and  $5 \times 10$ in. (127  $\times$  254mm) and  $5 \times 12$ in. (127  $\times$  305mm) cross section, and grouped in two series were tested in the experimental program. Series A consisted of seventeen plain concrete beams with a 7in. (178mm) wide symmetrical rectangular opening at midspan. The depth of the opening  $d_0$ , was varied from 2in. (51mm) to 6in. (152mm). Series B comprised six beams with a  $7 \times 4$ in. (178  $\times$  102mm) or a  $7 \times 5$ in. (178  $\times$  127mm) rectangular opening with horizontal and vertical steel around it. The beams also had top and bottom longitudinal reinforcements. Details of the beams are shown in Fig. 5.

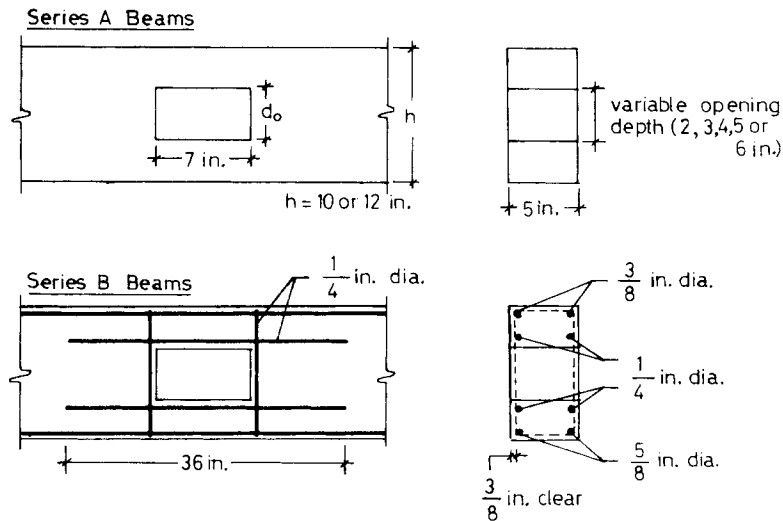

FIG. 5. Details of beams (1in. = 25.4mm).

The plain mild steel bars used were  $5/8$ in. (16mm),  $3/8$ in. (10mm) and  $1/4$ in. (6.4mm) in diameter having average yield strengths of 40.1 ksi (277 MPa), 47.7 ksi (329.1 MPa) and 53.8 ksi (371.2 MPa), respectively. Two different grades of concrete having nominal 28-day cylinder compressive strengths of 3 ksi (20.7 MPa) and 4.5 ksi (31.1 MPa) were used. The concrete mixes were designed using  $3/8$ in. (10mm) graded crushed rock and desert sand with a fineness modulus of 2.45.

The beams were tested in torsion only over an effective span of 8ft (2.44m). Special bearings were used under the supports to render the test specimen free to twist at one end, while the other end was held fixed against any torsional rotation. Torsional moment was applied in small increments by placing weights on hangers suspended from a centilever torsion arm attached to the twisting end of the test beam at the support.

### Discussion of Test Results

#### i. Series A

Figure 6 shows a typical failure pattern of plain concrete beams with a rectangular opening. The failure plane passed through two diagonally opposite corners of the opening, rather than forming a 45° continuous surface originating at one corner as suggested by Mansur and Hasnat<sup>[3]</sup>.



FIG. 6. Failure pattern of a plain concrete beam with a rectangular opening (Series A).

The test results are presented in Table 2. The experimental torsional moments are much smaller than the theoretical values obtained by using Eq. 13. The variation between the theoretical values and the experimental results depends on the  $d_o/h$  ratio. When the  $d_o/h$  ratio was varied from 0.20 to 0.50, the ratio  $T_{exp}/T_{theo}$  ranged from about 0.73 to 0.50. This variation was due to high stress concentration at the corners of the opening where the initial inclined cracks originated. Equation 13, thus, overestimates the torsional strength of plain concrete beams with a rectangular opening and is modified by introducing a strength reduction factor  $\phi$  as

$$T_{pch} = \phi 2 \sqrt{f'_c} b^2 h \left( 1 - \lambda \frac{d_o}{h} \right) \quad (34)$$

reinforced, the throat section needed further strengthening. This can be achieved by using short stirrups as done by Mansur and Hasnat<sup>[3]</sup>.

The factor  $\phi$  represents the  $T_{exp}/T_{theo}$  ratios in Table 2 and varies with  $d_o/h$  as shown in Fig. 7. In the figure a lower bound approach has been used to indicate the relationship between  $\phi$  and  $d_o/h$ .

TABLE 2. Results of Series A beams.

Beam	Opening depth $d_o$ (in.)	Overall beam cross-section $b \times h$ (in.)	Ratio $\frac{d_o}{h}$	Cylinder compressive strength $f'_c$ (psi)	Experimental torsional moment $T_{exp}$ (in.-kip)	Theoretical torsional strength $T_{theo}$ (in.-kip)	Ratio $\frac{T_{exp}}{T_{theo}}$
A-1	2	5 × 10	0.20	3350	16.8	23.2	0.72
A-2	2	5 × 10	0.20	3580	17.4	23.9	0.73
A-3	3	5 × 10	0.30	3580	14.4	20.9	0.69
A-4	3	5 × 10	0.30	3430	13.7	20.5	0.67
A-5	4	5 × 10	0.40	3430	10.5	17.6	0.60
A-6	4	5 × 10	0.40	3710	11.4	18.3	0.62
A-7	4	5 × 10	0.40	3710	11.4	18.3	0.62
A-8	5	5 × 10	0.50	3650	7.6	15.1	0.50
A-9	5	5 × 10	0.50	3650	7.9	15.1	0.52
A-10	3	5 × 12	0.25	4620	22.0	30.6	0.72
A-11	3	5 × 12	0.25	4620	21.4	30.6	0.70
A-12	4	5 × 12	0.33	4580	18.2	27.2	0.67
A-13	4	5 × 12	0.33	4580	19.1	27.2	0.70
A-14	5	5 × 12	0.42	4710	13.9	23.9	0.58
A-15	5	5 × 12	0.42	4710	14.1	23.9	0.59
A-16	6	5 × 12	0.50	4400	10.3	19.9	0.52
A-17	6	5 × 12	0.50	4400	10.9	19.9	0.55

1 in. = 25.4 mm.

1 psi = 0.0069 MPa.

1 in.-kip. = 0.113 kN-m.

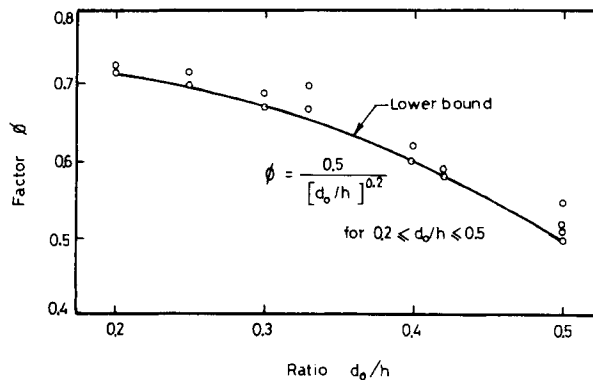
FIG. 7. Effect of  $d_o/h$  on strength reduction factor.

Since the torsional  $T_{ch}$  provided by concrete section with a rectangular opening is assumed as 40 percent of  $T_{pch}$ , Eq. 14 is also modified as

$$T_{pch} = \phi \cdot 0.8 \sqrt{f'_c} b^2 h \left( 1 - \lambda \frac{d_0}{h} \right) \quad (35)$$

Thus, Eq. 18 and 33 should be expressed as

$$T_{nh} = \phi \cdot 0.8 \sqrt{f'_c} b^2 h \left( 1 - \lambda \frac{d_0}{h} \right) + \frac{A_t \alpha_t x_1 y_1 f_y}{s} \left( 1 - \lambda \frac{d_0}{y_1} \right) \quad (36)$$

and

$$T_{nh} = \frac{\phi \cdot 0.8 \sqrt{f'_c} b^2 d}{\sqrt{1 + \left[ \frac{0.4 V_u}{C_t T_u} \right]^2}} \left( 1 - \lambda \frac{d_0}{h} \right) + \frac{A_t \alpha_t x_1 y_1}{s} (f_y - f_{svh}) \left( 1 - \lambda \frac{d_0}{y_1} \right) \quad (37)$$

It may be noted that Eq. 36 is for torsion and bending only and can be readily obtained from Eq. 37 by putting  $V_u = 0$  and  $f_{svh} = 0$ . The value of  $\phi$  for a rectangular opening can be obtained from Fig. 7. The value of  $\phi$  for a circular opening is established later.

## ii. Series B

In Series B beams, initial inclined cracks started at the two opposite corners of the opening. Their progress, however, was inhibited by the reinforcements provided around the opening. At a higher torsional moment, further inclined cracks passing through a lower corner, suddenly appeared in the upper unreinforced throat section leading to failure. The failure was accompanied by spalling of concrete from the upper throat section on the tension face where the later inclined cracks appeared (Fig. 8). The failure pattern indicates that although the corners had been adequately reinforced, the throat section itself needed further strengthening. This can be achieved by using short stirrups as done by Mansur and Hasnat<sup>[3]</sup>.

The general failure pattern is similar to that reported by Mansur and Hasnat<sup>[3]</sup> for their beams with reinforced throat section. However, they did not report any spalling of concrete.

The sudden appearance of inclined crack in the unreinforced throat section and its passing through a lower corner of the opening suggests that the value of  $n_h$  in Eq. 15 should be taken as discussed earlier.

Table 3 shows that the theoretical torsional moment capacities of the beams of Series B computed on the basis of Eq. 35 and 15 with  $\phi = 0.6$  and  $0.5$  for  $d_0/h = 0.4$

and 0.5, respectively, and  $n_h = 1.0$  i.e., the number of vertical stirrups on one side of the opening, are in very good agreement with the experimental results.

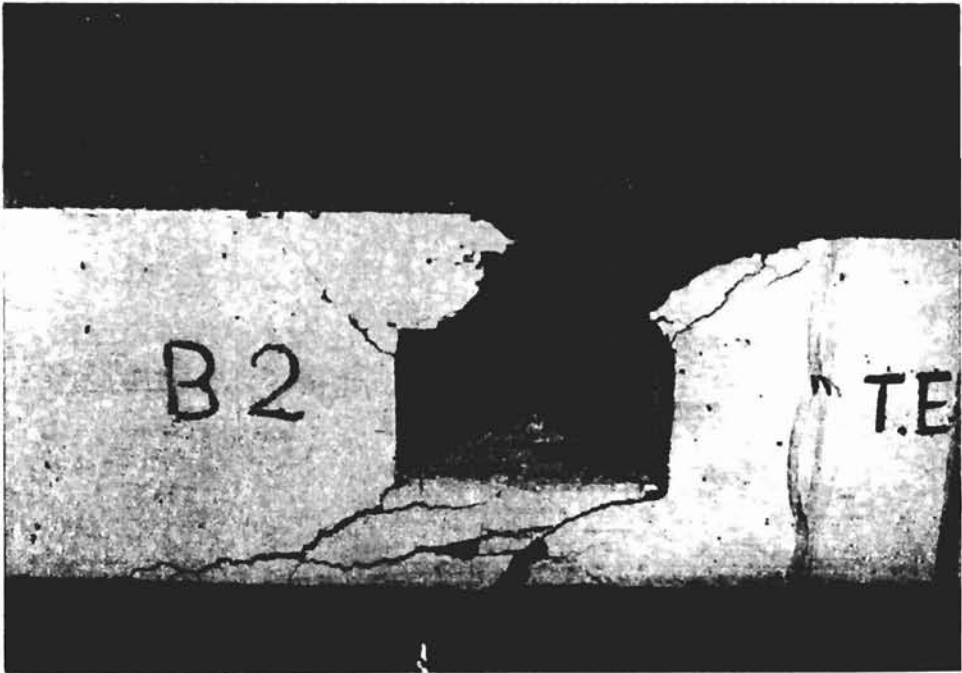

FIG. 8. Failure pattern of Series B beams.

TABLE 3. Results of Series B beams

Beam	Beam cross-section (in.)	Ratio $\frac{d_0}{h}$	Cylinder compressive strength $f'_c$ (psi)	Experimental torsional moment $T_{exp}$ (in.-kip)	Theoretical torsional strength $T_{theo}$ (in.-kip)	Ratio $\frac{T_{exp}}{T_{theo}}$
B-1	5 × 10	0.4	3430	19.2	19.0	1.01
B-2	5 × 10	0.4	3710	19.8	19.2	1.03
B-3	5 × 10	0.4	3580	19.6	19.1	1.03
B-4	6 × 10	0.5	4620	21.8	21.4	1.02
B-5	6 × 10	0.5	4580	22.3	21.4	1.04
B-6	6 × 10	0.5	4400	21.7	21.3	1.02

1 psi = 0.0069 MPa  
1 in.-kip = 0.113 kN-m

Mean = 1.025  
Standard deviation = 0.0105

### Comparison with Other Researchers' Data

The equations presented here can be verified against other available experimental data on beams containing a transverse opening. Table 4 compares the results obtained by Mansur and Hasnat<sup>[3]</sup> of plain concrete beams with a transverse circular opening with the theoretical torsional strengths obtained by Eq. 13. The table indicates that the torsional strength is slightly overestimated by the equation and a strength reduction factor  $\phi$  similar to that used for the beams with a rectangular opening is needed. However, unlike for the beams with a rectangular opening, the  $T_{exp}/T_{theo}$  ratios for the beams with a circular opening are, as shown in Table 4, independent of  $d_0/h$  ratio. The table also shows that a value of  $\phi = 0.9$  gives good correlation between the theoretical values and the test results with a mean of 1.04 and a standard deviation of 0.070. Thus, Eq. 34 with  $\lambda = \cos 45^\circ$  and  $\phi = 0.90$  can be used for beams with a circular opening.

TABLE 4. Comparison with Mansur and Hasnat's<sup>[3]</sup> data on plain concrete beams with a circular opening.

Beam	Opening diameter $d_0$ (in.)	Ratio $\frac{d_0}{h}$	Cylinder compressive strength $f'_c$ (psi)	Experimental torsional moment $T_{exp}$ (in.-kip)	Theoretical torsional strength $T_{theo}$ (in.-kip)	Ratio $\frac{T_{exp}}{T_{theo}}$	Ratio $\frac{T_{exp}}{0.9T_{theo}}$	Ratio $\frac{T_{exp}}{T_{theo}}$
3PA-1	3	0.3	6000	18.5	19.53	0.95	1.06	1.07
3PA-2	3	0.3	5860	17.5	19.30	0.91	1.01	1.02
3PA-3	3	0.3	7050	20.0	21.17	0.94	1.04	1.06
2PB-1	2	0.2	4560	18.0	18.55	0.97	1.07	1.09
2PB-2	2	0.2	4870	17.5	19.17	0.91	1.01	1.02
3PB-1	3	0.3	4620	16.0	17.14	0.93	1.03	1.05
3PB-2	3	0.3	4980	16.5	17.79	0.93	1.03	1.05
4PB-1	4	0.4	4560	13.5	15.50	0.87	0.97	0.99
4PB-2	4	0.4	4740	15.0	15.80	0.95	1.06	1.09
5PB-1	5	0.5	4980	14.0	14.60	0.96	1.07	1.12
5PB-2	5	0.5	4870	13.0	14.44	0.90	1.00	1.05
3PC-1	3	0.3	3630	14.0	15.19	0.92	1.02	1.04
3PC-2	3	0.3	3700	15.0	15.34	0.98	1.09	1.10

$T'_{theo}$  = Researchers<sup>[3]</sup> theoretical strength

1 in. = 25.4mm

1 psi = 0.0069 MPa

1 in.-kip = 0.113 kN-m

Mean = 1.04 1.06

Standard deviation = 0.070 0.036

Some available test results<sup>[3-5,7]</sup> on reinforced concrete beams with a transverse opening are compared, in Table 5, with their theoretical torsional strengths. All the beams listed were tested under torsion only. The torsional strength contribution due to concrete alone was computed by Eq. 35 and that due to steel by Eq. 15. For Beam 3RA-1<sup>[3]</sup> which had vertical stirrups adjacent to the opening only, the value of  $n_h$  in Eq. 15 was taken as 1.0 as discussed earlier under special case.

Beam RB-1<sup>[5]</sup> with a large rectangular opening had two different sizes of stirrups. The torsional strength contributed by the 10mm diameter stirrups adjacent to the large opening was computed separately, also by taking  $n_h = 1$ .

The torsional strength contribution due to the inclined bars around the circular opening in Beams CA-1, CA-2, CA-3 and CB-1<sup>[4]</sup> was computed by using Eq. 19 with values of  $\chi_1$  and  $\alpha_1$  for the inclined bars.

Table 5 shows that excellent agreement exists between the computed values and the experimental data for the beams with a mean  $T_{exp}/T_{theo}$  of 1.03 and a standard deviation of 0.114 confirming the validity of the relevant equations.

TABLE 5. Comparison with other researchers'<sup>[3-5,7]</sup> data of torsion tests on beams with a transverse opening.

From ref.	Beam	Opening size	Ratio $\frac{d_o}{h}$	Cylinder compressive strength $f'_c$ (psi)	Modulus of rupture $f_r$ (psi)	Experimental torsional moment $T_{exp}$ (in.-kip)	Observed failure mode	Researchers' theoretical torsional strength $T_{theo}$ (in.-kip)	Ratio $\frac{T_{exp}}{T_{theo}}$	Theoretical torsional strength $T_{theo}$ (in.-kip)	Ratio $\frac{T_{exp}}{T_{theo}}$	Strength reduction factor $\phi$
[3]	3RA-1	3in. dia	0.30	7050	485	22.0*	2	-	-	23.43	0.94	0.90
[7]	A1-1a	7 × 4 in.	0.40	3680	-	44.2	2	52.6	0.84	41.34	1.07	0.60
	A1-1b	7 × 4 in.	0.40	3330	-	44.9	2	52.6	0.85	41.12	1.09	0.60
	A2-1	7 × 4 in.	0.40	3380	-	52.8	2	62.2	0.85	41.15	1.28	0.60
[5]	RB-1	31.5 × 7.1 in.	0.45	5110	-	146.3	2	115.0	1.27	142.91	1.02	0.54
[4]	CA-1	4.13 in. dia	0.30	4320	-	165.7	2	151.5	1.09	166.59	0.99	0.90
	CA-2	5.51 in. dia	0.40	3900	-	156.2	2	139.6	1.12	153.41	1.02	0.90
	CA-3	6.89 in. dia	0.50	4610	-	131.1	2	128.5	1.02	143.10	0.92	0.90
	CB-1	7.09 in. dia	0.45	4900	-	241.5	2,3	223.0**	1.08	265.30	0.91	0.90

\*Failed in the unreinforced throat section

\*\*For Mode 3 failure

1 in. = 25.4 mm

1 psi = 0.0069 MPa

Mean = 1.03  
Standard deviation = 0.114

Table 6 compares three sets of available data<sup>[4,5,7]</sup> from torsion and bending tests on rectangular beams containing a transverse opening. The contribution due to the inclined bars around the opening of the beams of Series CB<sup>[4]</sup> was obtained by using Eq. 19. The computed torsional strengths have good agreement with the experimental results except for those beams tested at low  $T/M$  ratios. Excluding these results, the ratio  $T_{exp}/T_{theo}$  has a mean value of 1.11 and a standard deviation of 0.161.

The large variation between the computed values and the experimental results for beams tested at low  $T/M$  ratios shows that the equations need some modifications for use at low  $T/M$  ratios. This is because the ACI code equations themselves are not suitable for use at low  $T/M$  ratios. The  $T_{exp}/T_{theo}$  ratios have been plotted against the low  $T/M$  ratios in Fig. 9. It shows that a parabolic relationship exists between the variables, depending on  $d_o/h$  and the shape of the opening. At low ranges of  $T/M$  ratios, with  $T/M$  ratio at  $T_{exp}/T_{theo} = 1.0$  as the limit, the relationship can be expressed as

$$\frac{T_{exp}}{T_{theo}} = \left( \frac{1}{k} \psi \right)^\alpha \quad (38)$$



TABLE 6. Comparison with other researchers<sup>[4,5,7]</sup> data of torsion and bending tests on beams with a transverse opening.

From ref.	Beam	Opening size	Ratio $d_p/h$	Cylinder compressive strength $f_c$ (psi)	Experimental torsional moment $T_{exp}$ (in.-kip)	Experimental bending moment $M_{exp}$ (in.-kip)	Ratio $T_{exp}/M_{exp}$	Observed failure mode	Researchers' theoretical torsional strength $T_{theo}$ (in.-kip)	Ratio $T_{exp}/T_{theo}$	Strength reduction factor $\phi$	Theoretical torsional strength $T_{theo}$ (in.-kip)	Ratio $T_{exp}/T_{theo}$	Modified theoretical torsional strength $T_{theo}$ (in.-kip)	Ratio $T_{exp}/T_{theo}$
(7)	A1-2	7 x 4 in.	0.40	3600	51.6	55.1	0.94	2	52.6	0.98	0.60	41.29	1.25	41.29	1.25
	A1-3		0.40	3330	47.5	78.1	0.61	2	52.6	0.90	0.60	41.12	1.16	41.12	1.16
	A1-4		0.40	3600	49.3	152.6	0.32	1	50.9	0.97	0.60	41.29	1.19	41.29	1.19
	A1-5		0.40	3280	46.1	230.7	0.20	1	37.5	1.23	0.60	41.09	1.12	41.09	1.12
	A1-6		0.40	3280	26.7	266.8	0.10	1	21.0	1.26	0.60	41.09	0.65*	27.11	0.98
	A2-2		0.40	3910	54.5	90.8	0.60	2	62.2	0.88	0.60	41.47	1.31	41.47	1.13
	A2-3		0.40	3910	52.3	174.8	0.30	1	49.0	1.07	0.60	41.47	1.26	41.47	1.26
	A2-4		0.40	2900	41.5	211.2	0.20	1	37.5	1.11	0.60	40.85	1.02	40.85	1.02
	A2-5		0.40	3460	26.7	257.3	0.10	1	21.0	1.27	0.60	41.21	0.65*	27.19	0.98
	Mean												1.19	1.14	
Standard deviation												0.098	0.125		
(5)	RB-2	15.75 x 7.09 in.	0.45	5110	141.2	74.3	1.90	2	128.3	1.10	0.54	142.91	0.99	142.91	0.99
	RB-3		0.45	5160	177.0	162.4	1.09	2	141.6	1.25	0.54	142.99	1.24	142.99	1.24
	RB-4		0.45	5390	188.5	401.1	0.47	2	181.4	1.04	0.54	143.36	1.31	143.36	1.31
	RB-5		0.45	5390	142.1	592.2	0.24	2	132.7	1.07	0.54	143.36	0.99	139.61	1.02
	RB-6		0.45	4870	84.1	700.6	0.12	1	69.0	1.22	0.54	142.52	0.59*	88.45	0.95
Mean												1.13	1.10		
Standard deviation												0.167	0.162		
(4)	CB-2	7.09 in. dia	0.45	5370	244.9	104.7	2.34	1,2	241.9	1.01	0.90	266.86	0.92	266.86	0.92
	CB-3		0.45	6120	265.9	246.2	1.08	1,2	229.7	1.16	0.90	269.24	0.99	269.24	0.99
	CB-4		0.45	4800	209.2	445.1	0.47	1	187.3	1.12	0.90	264.94	0.79	221.67	0.94
	CB-5		0.45	4950	171.7	715.4	0.24	1	142.8	1.20	0.90	265.47	0.65*	153.47	1.12
	CB-6		0.45	4800	99.6	830.0	0.12	1	89.1	1.12	0.90	264.94	0.38*	104.62	0.95
	Mean												0.90	0.98	
Standard deviation												1.01	0.080		
Overall Mean												1.11	1.08		
Overall Std. devn.												0.161	0.126		

\* Excluded from the mean and standard deviation calculations.

1 in. = 25.4mm  
 1 psi = 0.0069 MPa  
 1 in.-kip = 0.113 kN-m

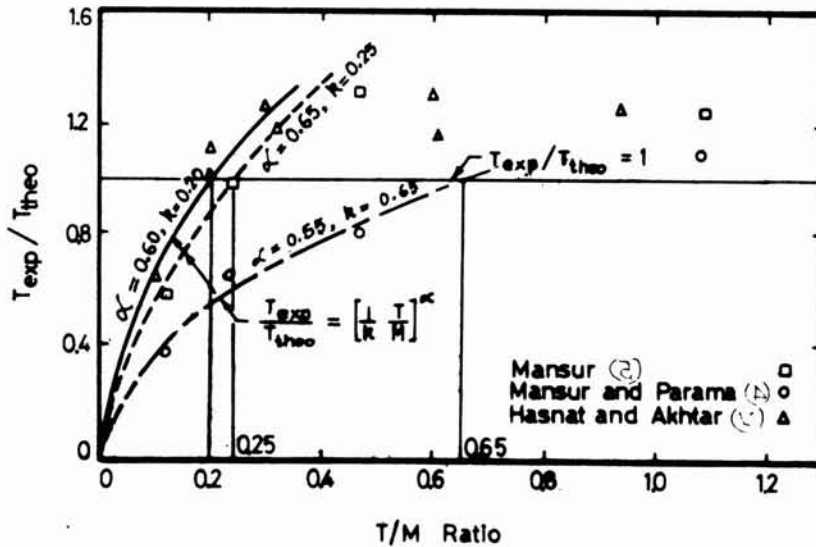

FIG. 9. Effect of  $T/M$  ratio on  $T_{exp}/T_{theo}$  for beams tested under torsion and bending.

The values of the coefficient  $k$  and the index  $\alpha$  as well as the limiting  $T/M$  ratios ( $\psi$ ) for the three sets of experimental data, as obtained from Fig. 9, are presented in Table 7. It shows that all of these depend on  $d_0/h$  and also on the shape of the opening.

TABLE 7. Values of  $k$ ,  $\alpha$  and  $T/M$  limits.

For data from ref	Opening shape	Ratio $\frac{d_0}{h}$	$k$	$\alpha$	Limiting value of $T/M$
[7]	rectangular	0.40	0.20	0.60	0.20
[5]	rectangular	0.45	0.25	0.65	0.25
[4]	circular	0.45	0.65	0.55	0.65

Following Eq. 38, the torsional strength at low  $T/M$  ratios can be obtained as  $(1/k T/m)^\alpha T_{theo}$  where  $T_{theo}$  is given by Eqs. 35, 15 and 19. The last two columns of Table 6 compare the experimental results with the modified theoretical values  $T''_{theo}$ . As can be seen,  $T_{exp}/T''_{theo}$  has an overall mean of 1.08 and a standard deviation of 0.126 to indicate a good agreement between the theoretical and the experimental results.

Data on beams tested under torsion, bending and shear are rather scarce. Two sets of published data are compared with theoretical strengths in Table 8. One set comprises data on rectangular beams with a small rectangular opening<sup>[7]</sup> and the second set consists of data on rectangular beams of solid section<sup>[12]</sup>. The theoretical torsional strengths of the former have been computed by Eq. 37 and for the latter by Eq. 26. The results are presented in Table 8. It shows that for the beams with a rectangular opening, the torsional strengths are significantly underestimated, especially in the lower ranges of  $T/M$  ratios. For these beams,  $T_{exp}/T_{theo}$  has a mean value of 1.39 and a standard deviation of 0.164. Table 8, however, shows that for the beams with solid cross-section, the theoretical values, with the exception of Beams 7-3 and 7-4, are in good agreement with the experimental results. With these two data excluded,  $T_{exp}/T_{theo}$  has a mean value of 0.95 and a standard deviation of 0.126 which compare well with the researchers<sup>[12]</sup> values of 0.92 and 0.080, respectively.

The  $T_{exp}/T_{theo}$  versus  $T/M$  ratio plots for the beams are presented in Fig. 10. It shows that at low  $T/M$  ratios, i.e.,  $T/M \leq 1.0$ , the  $T_{exp}/T_{theo}$  versus  $T/M$  ratio plot for the beams with a rectangular opening can be represented by

$$\frac{T_{exp}}{T_{theo}} = 1.15 \psi^{-0.3} \quad (39)$$

where  $T_{theo}$  is given by Eq. 37.

TABLE 8. Comparison with other researchers<sup>[7,12]</sup> data of torsion, bending and shear tests on beams with and without a transverse opening.

From ref.	Beam	Opening size	Ratio $d_o/h$	Cylinder compressive strength $f_c$ (psi)	Experimental torsional moment $T_{exp}$ (in.-kip)	Experimental bending moment $M_{exp}$ (in.-kip)	Shear force $V_{exp}$ (kip)	Ratio $T_{exp}/M_{exp}$	Ratio $T_{exp}/V_{exp}$	Ratio $M_{exp}/V_{exp}$	Observed failure mode	Researchers' theoretical torsional strength $T_{theo}$ (in.-kip)	Ratio $T_{exp}/T_{theo}$	Theoretical torsional strength $T_{theo}$ (in.-kip)	Ratio $T_{exp}/T_{theo}$	Modified theoretical torsional strength $T_{theo}^*$ (in.-kip)	Ratio $T_{exp}/T_{theo}^*$		
[7]	B1-1	7 × 4in.	0.4	3625	49.93	20.10	1.47	2.48	33.97	13.68	2	48.94	1.02	37.60	1.33	37.60	1.33		
	B1-2			3625	44.22	44.23	3.26	1.00	13.56	13.58	2	44.47	0.99	33.14	1.33	38.11	1.16		
	B1-3			3254	44.83	74.93	5.53	0.60	8.11	13.55	2	38.78	1.16	27.06	1.66	36.27	1.24		
	B1-4			3254	36.01	87.70	6.48	0.41	5.58	13.54	2	36.42	0.99	24.90	1.45	37.42	0.96		
	B1-5			3568	17.95	188.46	13.94	0.095	1.29	13.52	1	17.69	1.01	6.87	2.61*	16.01	1.12		
	B2-1			3490	49.71	19.97	0.70	2.49	70.71	28.41	2	50.85	0.98	39.47	1.26	39.47	1.26		
	B2-2			3490	46.71	46.79	1.72	1.00	27.24	27.28	2	48.32	0.97	36.90	1.27	42.44	1.10		
	B2-3			3278	45.82	76.23	2.83	0.60	16.21	26.97	2	45.54	1.01	33.94	1.35	45.50	1.01		
	B2-4			3278	44.19	147.57	5.52	0.30	8.01	26.74	1.2	38.81	1.14	27.12	1.63	44.75	0.99		
	B2-5			3512	28.38	189.70	7.11	0.15	3.99	26.68	1	27.81	1.02	23.90	1.19	48.55	0.58*		
Mean												1.03		1.39		1.13			
Std. dev.												0.066		0.164		0.129			
[12]	S-1	0 × 0in.	0.0	5710	128.00	65	0.76	1.97	168.42	85.49	3	151	0.85	150.69	0.85		0.85		
	S-2			6370	141	143	1.89	0.99	74.60	75.35	2.3	178	0.79	149.05	0.95		0.95		
	S-3			6060	130	278	3.87	0.47	33.59	71.47	1	141	0.92	142.81	0.91		0.91		
	S-4			5800	99	389	5.51	0.25	17.97	71.88	1	98	1.01	138.19	0.72		0.72		
	6-1			5860	129	65	1.81	1.98	71.27	35.99	3	140	0.92	148.12	0.87		0.87		
	6-2			5930	145	149	4.27	0.97	33.96	35.01	3.2	153	0.95	141.22	1.03		1.03		
	6-3			5700	132	264	7.67	0.50	17.21	34.42	1	157	0.84	131.09	1.01		1.01		
	6-4			5720	107	427	12.45	0.25	8.59	34.36	1	104	1.03	118.42	0.90		0.90		
	7-1			6080	112	56	1.56	2.00	71.79	35.89	3	108	1.03	105.64	1.06		1.06		
	7-2			5210	115	115	3.32	1.00	34.64	34.64	3	125	0.92	98.48	1.17		1.17		
	7-3			5700	132	275	8.11	0.48	16.28	33.92	3.2	154	0.86	85.79	1.54*		1.54*		
	7-4			5340	125	505	14.97	0.25	8.35	33.40	1.2	132	0.95	64.50	1.94*		1.94*		
	Mean												0.92		0.95				
	Std. dev.												0.077		0.126				

\* excluded from the mean and standard deviation calculations.

1 in. = 25.5 mm  
 1 psi = 0.0069 MPa  
 1 in.-kip = 0.113 kN-m

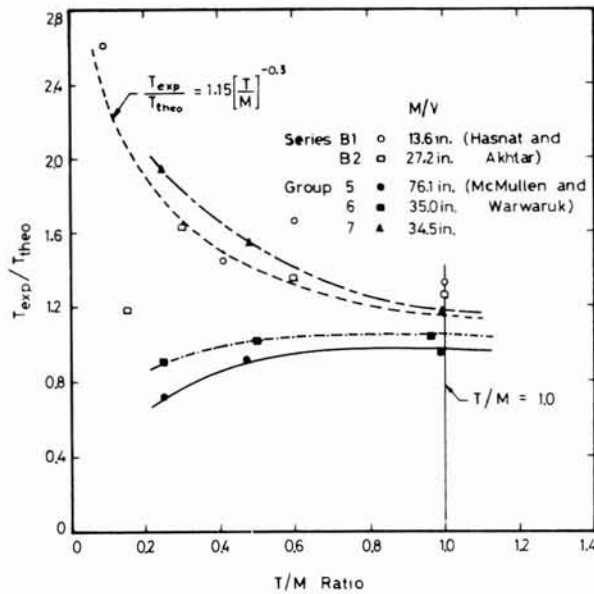

FIG 10. Effect of  $T/M$  ratio on  $T_{exp}/T_{theo}$  for beams tested under torsion, bending and shear ( $l_o = 25.4\text{mm}$ ).

Following Eq. 39, the torsional strength at low  $T/M$  ratios can be obtained as  $1.15 \psi^{-0.3} T_{theo}$ . In the last two columns of Table 8, the experimental results are compared with the theoretical strengths given by Eq. 37 as well as by Eq. 39 for low  $T/M$  ratios. Except for one result of Beam B2-5, the results are in good agreement with the theoretical values. With the said data excluded,  $T_{exp}/T_{theo}$  has a mean of 1.13 and a standard deviation of 0.129.

Figure 10 indicates that at low  $T/M$  ratios, a relationship similar to Eq. 39 exists for the Group 7 beams of solid cross-section. The plots for Groups 5 and 6 beams, however, have an opposite curvature. This is possibly because the beams of Group 7 had a smaller  $A_s/A_s'$  ratio ( $= 0.14$ ) compared to the beams of Groups 5 and 6 ( $= 0.25$ ) and were thus more susceptible to Mode 3 failure. Further research, however, is required in this direction for a definitive conclusion.

### Conclusion

The ACI code torsion equations for beams of solid cross-section have been modified to predict the torsional strength of rectangular beams with a transverse opening. The equations are also adapted for use at  $T/M$  ratios by taking into consideration the effect of torsion-bending interaction. The torsional strengths predicted by the modified equations are compared with available test results of beams with a circular as well as with a rectangular transverse opening. Excellent correlation is observed between the predicted values and the experimental results of the beams tested under various combinations of torsion, bending and shear at all ranges of  $T/M$  ratios. This confirms the validity of the modifications.

### Acknowledgments

The experimental work described in this paper was carried out at the Civil Engineering Department, Faculty of Engineering, King Abdulaziz University, Jeddah, Saudi Arabia, under a research grant sponsored by the Scientific Research Administration of the Faculty of Engineering.

### Notation

$A_d$	=	area of an inclined bar around an opening, in <sup>2</sup> .
$A_s, A_s'$	=	area of bottom and top longitudinal steel, respectively, in <sup>2</sup> .
$A_t$	=	area of one leg of a vertical stirrup, in <sup>2</sup> .
$A_v$	=	area of two legs of a vertical stirrup, in <sup>2</sup> .
$b$	=	beam width, in.
$b_0$	=	width of a rectangular opening in the beam web, in.
$C_t$	=	factor relating shear and torsional stress properties, in <sup>-1</sup> .
$d$	=	effective depth of beam section, in.
$d_0$	=	depth of a rectangular opening; diameter of a circular opening, in.
$f_c'$	=	compressive strength of concrete, psi.

$f_r$	=	modulus of rupture of concrete, psi.
$f_{sv}, f_{svh}$	=	stress in stirrup due to shear force in the solid section and the hole section, respectively, psi.
$f_y$	=	yield strength of stirrup steel, psi.
$h$	=	overall depth of beam section, in.
$k$	=	coefficient.
$M$	=	bending moment, in.-kip.
$n, n_h$	=	number of stirrups intersected by an inclined failure plane through the solid section and the hole section, respectively.
$n_d$	=	number of inclined bars around an opening, intersected by an inclined failure plane.
$s$	=	spacing of stirrups, in.
$T$	=	torsional moment, in.-kip.
$T_c, T_{ch}$	=	nominal torsional strength contributed by concrete at solid section and hole section, respectively, in.-kip.
$T_{dsh}$	=	nominal torsional strength provided by inclined bars around a circular opening, in.-kip.
$T_n, T_{nh}$	=	nominal torsional strength of a beam of solid section and containing an opening, respectively, in.-kip.
$T_{pc}, T_{ch}$	=	nominal torsional strength of a plain concrete beam of solid section and containing an opening, respectively, in.-kip.
$T_s, T_{sh}$	=	nominal torsional strength provided by torsional reinforcement in a beam of solid section and containing an opening, in.-kip.
$T_u$	=	factored torsional moment at a section, in.-kip.
$V_c, V_{ch}$	=	nominal shear strength provided by concrete at solid section and hole section of a beam, respectively, kip.
$V_n, V_{nh}$	=	nominal shear strength of a beam of solid section and containing an opening, respectively, kip.
$V_s, V_{sh}$	=	nominal shear strength provided by shear reinforcement at solid section and hole section, respectively, kip.
$V_u$	=	factored shear force at section, kip.
$x_1, y_1$	=	shorter and longer center-to-center dimensions of stirrups, respectively, in.
$\alpha$	=	index of equation.
$\alpha_t$	=	coefficient as a function of $y_1/x_1$ .
$\theta$	=	inclination of failure plane with vertical on tension side, degree.
$\theta'$	=	inclination of inclined bars around an opening, degree.
$\phi$	=	strength reduction factor.
$\psi$	=	ratio $T/M$ .
$\lambda$	=	factor.

#### References

- [1] **ACI Committee 318**, *Building Code Requirements for Reinforced Concrete (ACI 318-83)*, American Concrete Institute, Detroit, 111 p. (1983).

- [2] **Hsu, T.T.C.**, Torsion of Structural Concrete – Behavior of Reinforced Concrete Rectangular Members, in: *Torsion of Structural Concrete, ACI Special Publ. SP-18*, pp. 261-305 (1968).
- [3] **Mansur, M.A.** and **Hasnat, A.**, Concrete Beams with Small Opening under Torsion, *Proceedings, American Society of Civil Engineers*, **105**(ST 11): 2433-2447 (1979).
- [4] **Mansur, M.A.** and **Paramasivam, P.**, Reinforced Concrete Beams with a Small Opening in Bending and Torsion, *Journal of the American Concrete Institute*, Proceedings, **81**(2): 180-185 (1984).
- [5] **Mansur, M.A.**, Combined Bending and Torsion in Reinforced Concrete Beams with Rectangular Openings, *Concrete International: Design & Construction*, **5**(11): 51-58 (1983).
- [6] **Hasnat, A.** and **Akhtaruzzaman, A.A.**, An Experimental Investigation to Determine the Ultimate Strength of Reinforced Concrete Beams Containing an Opening under Bending and Torsion, *Final Report, Research Project No. 01-21, Scientific Research Administration, Faculty of Engineering, King Abdulaziz University, Jeddah, Saudi Arabia*, pp. 1-74 (1983).
- [7] **Hasnat, A.** and **Akhtaruzzaman, A.A.**, Reinforced Concrete Beams with a Small Rectangular Opening under Torsion, Bending and Shear, *Journal, Structural Division, American Society of Civil Engineers*, **113** (10): 2253-2270 (1987).
- [8] **Winter, G.** and **Nilson, A.H.**, *Design of Concrete Structures*, 9th ed., McGraw-Hill Book Company, New York, pp. 170-185 (1979).
- [9] **Hsu, T.T.C.**, Torsion of Structural Concrete – Plain Concrete Rectangular Sections, Torsion of Structural Concrete, SP-18, American Concrete Institute, Detroit, pp. 203-238 (1968).
- [10] **Collins, M.P.**, **Walsh, P.F.**, **Archer, F.E.** and **Hall, A.S.**, Ultimate Strength of Reinforced Concrete Beams Subjected to Combined Torsion and Bending, Torsion of Structural Concrete, SP-18, American Concrete Institute, Detroit, pp. 379-402 (1968).
- [11] **Lessig, N.N.**, Determination of Load Carrying Capacity of Reinforced Concrete Elements with Rectangular Cross-section Subjected to Flexure with Torsion, Trudy No. 5, Concrete and Reinforced Concrete Institute, Moscow, pp. 5-28 (1959).
- [12] **McMullen, A.E.** and **Warwaruk, J.**, Concrete Beams in Bending, Torsion and Shear, *Proceedings, American Society of Civil Engineers*, **96**(ST 5): 885-903 (1970).

## تعديل معادلات معهد الخرسانة الأمريكي لأداء لي العتبات المستطيلة المقطع ذوات الفتحات

علي أمجد أخت الزمان

قسم الهندسة المدنية ، كلية الهندسة ، جامعة الملك عبد العزيز

جدة ، المملكة العربية السعودية

تحتوى هذه الدراسة على تعديل لمعادلات اللي في قوانين ACI للعتبات الخرسانية المصمتة بحيث يمكن استعمالها في التنبؤ بمقاومة التواء العتبات ذات المقاطع المستطيلة والمزودة بفتحات عرضية . وكذلك فقد تم تعديل المعادلات نفسها أيضاً لتشمل التأثير المزدوج للي والانحناء في حالة قيم منخفضة من نسبة عزم اللي إلى عزم الانحناء .

ويمقارنة المعلومات الناتجة عن اختبار إحدى وخمسين عتبة - أخضع كل منها لمجموعة مختلفة القيم من اللي والانحناء والقص - بالقيم المحسوبة من المعادلات المعدلة ، تبين موافقة جيدة بينهما لكل القيم المختلفة لنسبة عزم اللي إلى عزم الانحناء (T/M) . كما نعرض لتنتائج التجارب التي أجريت على ثلاث وعشرين عتبة ، بعضها مصنوع من الخرسانة الصرفة والبعض الآخر مسلح تسليحاً جزئياً ، وكلها مزود بفتحات مستطيلة .