

## Factors of Production and Factor Returns Under Political Economy of Islam

SHAMIM AHMAD SIDDIQUI  
*Assistant Professor*  
*University of Brunei Darussalam*

**Abstract.** This paper critically reviews the traditional classifications and definitions of different factors of production and the way their returns are determined under neoclassical framework. It also analyses some suggested changes in these definitions made by contemporary Muslim economists. The issue of land ownership, land-rent and share cropping is discussed in historical and Islamic perspective. An attempt is made to synthesize competing theories of demand and supply of labor and wage determination. The issue of physical and monetary capital is discussed both in the traditional and an Islamic context. Finally, the importance of the role of entrepreneurship, particularly for an Islamic economic system, is emphasized.

### I. Introduction

An important aspect of any economic system is its classification and definition of different factors of production and the way the total output of the economy is distributed among these factors. If the postulates of Islamic economics are different from the neoclassical economics, it is only natural that an Islamic economic system would have some differing views on the issue of factors of production and their returns. The issue in its totality has, however, received relatively less importance by the proponents of Islamic economic system. Furthermore, the small volume of contemporary literature on the topic clearly shows that, like western economic thinking, there are vast differences of opinion among Muslim economists<sup>(1)</sup>.

The contemporary western economic literature, dominated by neoclassical school of thought, generally recognizes four distinct factors of production<sup>(2)</sup>; labor, land, capital and

---

(1) Samuelson and Nordhaus, have noted that issues surrounding the distribution of income are among the most controversial in all economics (**P. Samuelson** and **William D. Nordhaus**, *Economics*, 12th edition, International Student edition, National Printers (Ptc.) Ltd., Singapore, 1985, p. 561)

(2) Baumol and Blinder treat exhaustible natural resources as a separate factor of production to distinguish it from land (**Baumol** and **Blinder**, 1991, p. 740)

entrepreneurship and their rewards as wages, rent, interest and profit, respectively. According to this school, wages, rent and interest are determined through the demand and supply in the respective markets of factors of production. While the supply sides of the markets for labour, land and capital differ enormously from one another, one basic principle, the principle of marginal productivity, has been used to explain the demand for every input<sup>(3)</sup>. However, even those critics of neoclassical economics who generally accept the neoclassical classification of factors of production, have questioned the plausibility of marginal productivity principle in determining the reward for factors of production<sup>(4)</sup>. Many critics claim that it explains nothing, is unrealistic and refers to nothing measurable<sup>(5)</sup>.

There are three primary objectives of this paper. (i) To suggest changes in the traditional definitions of some of the factors of production (ii) to give some new insights about the way returns to factors are determined or ought to be determined especially with reference to labor, and (iii) who is the rightful recipient for the payment of a factor of production under political economy of Islam. In order to achieve our objectives, we critically review the classification and definitions of each factor of production given by the neoclassical school and contemporary Muslim economists. Although, this exercise may produce further controversies among Muslim economists, it is hoped that these altercations would eventually lead to an improved understanding of the subject.

## II. Land and Land-Rent

In the contemporary western economic literature, land refers to the resources provided by nature, e.g. space, rain and minerals<sup>(6)</sup>. Some economists, therefore, prefer to use the term *natural resources* over *land* for this category of resources<sup>(7)</sup>. Baumol and Blinder treat exhaustible natural resources as a separate factor of production to distinguish it from land<sup>(8)</sup>. On the other hand, it is now a common practice to regard rent or pure economic rent as a payment to a factor of production whose supply is fixed. Thus, according to Samuelson and Nordhaus, whether it is a piece of land or the famous late night talk show host Johnny Carson of California, their price should be treated as rent<sup>(9)</sup>.

Although land is generally treated as either part of natural resources or its meaning is broadened to include other natural resources, we propose that it should be treated exclusively for agriculture, commercial and residential land. Natural resources could be defined as those resources of an economy which can be freely used by any member(s) of the society or by the state, whose ownership belongs to the society as a whole and no payments are made for the use of these resources. The examples can be air space, rivers, forests, pasture, plain land, etc<sup>(10)</sup>. All the four conventional factors of production, labor, land, capital and entrepreneurs can

---

(3) **Baumol** and **Blinder** (1991), p. 741.

(4) An excellent non Marxian critique is *Capital for Profit* by **Paul Fabra** (1991).. The radical views could be found in **E. K. Hunt** and **Howard J. Sherman** (1975)., pp. 249-50.

(5) **Baumol** and **Blinder** (1991), p. 888.

(6) **Harvey** (1988), p. 74

(7) For example **Barrow** and **Lynch** (1993)., p. 11

(8) **Baumol** and **Blinder** (1991)., p. 740.

(9) **Samuelson** and **Nordhaus** (1985)., p. 603

(10) Although, it is possible that the state may grant, sell or rent a part of a river or forest to an individual or a group of individuals. Similarly, it may bring a piece of land under its own control denying free access to the public. The land then cease to be a public or collective property or natural resource.

benefit from the natural resources. Similarly, the term land-rent should be used for the payment of agricultural land or a piece of land used for commercial or industrial purpose without any permanent structure. It is clear that rent of residential, commercial or industrial structures, apart from the gross return on capital invested in the structure, implicitly include land-rent of the land on which the structures stand. Alfred Marshall, the synthesizer of classical and marginalist ideas, introduced the concept of quasi-rent for remuneration to fixed inputs (e.g., plants, buildings, machines) other than land<sup>(11)</sup>. In this way he was able to keep the classical definition of rent as a payment to land. However, as rent is now so widely used to mean payment for different capital goods, it would be convenient to denote payment to land (as we have defined it) *land-rent*. This way *rent* could be left to mean different things in a particular contexts<sup>(12)</sup>.

In the western economic tradition the issue of land and land rent has now been settled. Any piece of land in a western society belongs to one of the following: an individual, group of individuals, private institutions or a particular tier of government or its agencies. Furthermore, most of the land belongs to individuals and ownership of land is, by and large, absolute. If the government needs a land for public use, it normally acquires the land at the prevailing market prices generally after the consent of the owners. The situation of most developing countries including Muslim countries is not very different except that when they decide to acquire privately owned land they normally take it on an arbitrary and lower than market price.

The issue of property ownership in the western society goes back to Aristotle who argued for private land ownership on efficiency ground. According to him, communal property will not be looked after as carefully as private property. In addition, quarrels are bound to develop when men, unequal by nature in skill and industry, are not differentiated by varying opportunities of enjoyment<sup>(13)</sup>. He was also against any physical limitation as it would create many practical difficulties. If the community needed a piece of land, the lawful authority would have been allowed to acquire the land<sup>(14)</sup>. It is the use, according to Aristotle, to which property is put that is of the highest moral significance. People always want more and more and any attempt to abolish private property or to equalize it would not be helpful<sup>(15)</sup>. His solution was to educate people and form institutions which would limit the unlimited desire of people to acquire land and could share some of their property with their friends and leave some thing for common use.

The Roman law on the other hand made two things very clear: they allowed rights of private property almost without limit and guaranteed freedom of contract. The Gospels and the early fathers of Christianity, however, had much more revolutionary views on these issue. To them, struggle to acquire wealth and property was worthless; salvation in the hereafter was the important thing. But as the Roman empire faltered, it relied more and more on the support of frontier chieftains who were rewarded with big chunks of land. Similarly in other areas of Europe, with or without the contact of the Romans, the feudal system evolved. The main catalyst for that were the conquerors who gave away and legitimized ownership of land to their previous and future supporters<sup>(16)</sup>.

---

(11) **Stigler** (1987), pp. 263-65.

(12) For example, car rent of rent for a machine.

(13) **Roll** (1973), p. 31.

(14) **Spiegel** (1991), p. 29.

(15) **Spiegel** (1991), p. 29.

(16) **Roll** (1973), p. 42.

Although the Church favored communal ownership of property as a way of salvation, in many places it itself became the greatest holder of land and eventually integrated into the feudal societies of the west. The great scholastic writers of the thirteenth and the fourteenth centuries, realized the importance of private ownership of property. By that time they had also access to the writings and ideas of the Greek philosophers which they combined with the teachings of Gospels and legitimized private ownership of land. The feudal system in the western world, which was mainly based first on slave labor and then on semi slave institutions of tenants and wage labor, changed with the growth of towns which necessitated trade and commerce. The industrial revolution reduced the relative importance of agriculture. Alternative job opportunities to wage workers and tenants marginalised the economic power of landlords. Agriculture eventually became just another industry.

In the western economic tradition, the issue of rent has also been solved, perhaps once for all. Rent of any piece of land is determined through the market process and the owner of the land receives the rent. The fact that, at times the increase in rent is largely a consequence of increased population or increased commercial activities in a particular area or region to which no contribution is rendered by the owner of the land, is generally ignored. For example, Samuelson and Nordhaus apparently do not find any flaw in the argument put forward by Henry George in the late nineteenth century United States about heavy taxation of land rent. According to George, taxing this unearned income could provide such an enormous amount to the government that no other tax would be needed. But without giving their own opinion on the issue in the context of contemporary capitalist system, Samuelson and Nordhaus simply state that "... it is not likely that any one running on the single tax-ticket will again come so close to being elected mayor of New York city as George did in 1886. Nor is it likely that any one will soon come along and write so persuasive a bible for the movement as Henry George did in his *Progress and Poverty*, a book which sold millions of copies"<sup>(17)</sup>. It is generally understood that in the neoclassical tradition income disparity is tolerated only to acquire higher efficiency. Here is a case which denies that assertion!

### **The Issue of Land and Land-Rent in Islam**

#### ***Agricultural Land***

To begin our discussion of land and land rent in Islam, we go back to the teachings of the Qur'an and the Sunnah of the Prophet (Peace be upon him). As far as the Qur'an is concerned, according to our limited knowledge, there is no detail given how to manage and allocate land in a Muslim society. However, Islamic economists have derived two main principles from the following verses of the Qur'an: (a) 'Unto Allah (belongeth) whatsoever is in heavens and whatsoever is in earth' (II:284), (b) 'Hast thou not seen how Allah hath made all that is in the earth subservient unto you?' (XXII:65), and (c) 'Believe in Allah and his messenger, and spend of that whereof He had made you trustee' (LVII:7)<sup>(18)</sup>. According to Behdad, (a) and similar verses in the Qur'an justify the agreement among Muslim economists about the ultimate ownership of property by Allah. The other two verses provide the notion of trusteeship of man and man's accountability to God which reconciles the dichotomy of God-Man ownership<sup>(19)</sup>.

---

(17) Samuelson and Nordhaus (1985), pp. 604-5.

(18) Behdad (1992), p. 79.

(19) *Ibid.* (1992), p. 79.

Behdad quotes the following verse of the Qur'an to emphasize that plain land (land in its natural form) can not be owned by individuals. 'Lo! the earth is Allah's. He giveth it for an inheritance to whom He will' (VII:128). He also mentions that there is little disagreement about this among Islamic economists. One may claim priority in use of plain land by improving it with one's labor and capital. This priority, however, may be conditional to the continued use of land. According to a Hadith of the Prophet, 'Land belongs to God, whoever leaves it uncultivated for three consecutive years will have it taken away and given to someone else'<sup>(20)</sup>. There are, however, controversies over following related issues:

- a) Can a person use wage or slave labor to claim priority in use?
- b) Can this claim be sold or bequeathed i.e., can he become owner of the land?
- c) If a person does not or cannot cultivate the land himself, can he give the land to someone else on rent? What about wage labour and share cropping?
- d) Is it possible for an Islamic government to put a ceiling on land holding? If so, under what circumstances?

Following the labour theory of value, some Muslim economists suggest that a person can claim priority in use only if he applies his own labour. But generally they agree that one can use his financial capital or wage labour to claim priority in use. It would be interesting to see why in the first place, a person would offer his labour to someone for a wage when he can himself claim the priority in use if he works on his own? Unless he is a slave or urgently needs basic necessities of life (i.e., food or clothing), he would not agree to do that. In an Islamic state this situation should not arise and hence even if one answers question (a) above in affirmative, it becomes irrelevant.

The majority of Muslim economists also believes that priority of use is synonymous to ownership of land which can be sold or bequeathed<sup>(21)</sup>. They, however, insist that there is no absolute ownership in Islam. Whenever and wherever necessary, land could be acquired by the state for the cause of the society as a whole<sup>(22)</sup>. Those who believe that the Islamic right of ownership is one of utilization and not of possession, argue that as soon as a worker ceases activity on his land, the right of utilization could be transferred to one who is ready to cultivate the land. Following this logic, an extreme argument is made against right to sell or bequeath<sup>(23)</sup>. The later argument could be refuted if it can be established that the *Shar'ia* permits a person to rent the land he improved upon. The legitimacy of sale or bequest of a piece of land would then follow<sup>(24)</sup>.

---

(20) See **Behdad** (1992), p. 87.

(21) **Nomani** and **Rahnema** (1994), p. 74.

(22) *Ibid.* (1994), p. 70.

(23) *Ibid.* (1994), p. 74. who site, Sadr, Kahf and Taleqani.

(24) However, using the arguments we present in the following paragraphs in our discussion of land rent, in case the land is sold at market price rather than bequeathed, an Islamic state must formulate a mechanism to calculate and tax away a part of the price which is due to the scarcity of land.

Land-rent on agricultural land and share cropping are other two controversial issues which has divided Muslim economists into different camps. Moreover, all of them can find their respective positions validated by the *Shar'ia*. To have a clear understanding, we present the following Ahadith:

i) "He who has land should cultivate it. If he will not or cannot, he should give it free to a Muslim brother and not rent it to him<sup>(25)</sup>.

ii) Al-Bukhari reported that the Prophet said, "If it is not given gratis to your brethren or is kept idle (i.e. uncultivated), it is better to give for cultivation in return for a fixed rent (or share of the produce)"<sup>(26)</sup>.

iii) Another Hadith narrated by Sa'd Ibn Abi Waqqas says, 'We used to rent land and pay the owner as rent the produce grown on the banks of irrigation canals. The Prophet prohibited this and ordered us to pay rent in gold or silver'<sup>(27)</sup>.

iv) Al-Bukhari reported that Ibn Abbas said "The Prophet had not, in fact, prohibited (all forms of share tenancy) but had only diverted attention to the fact that it was better to give land gratis to any of your brothers than to receive a fixed rent of the land"<sup>(28)</sup>.

v) Abdullah bin Mufaddal reported from Thabit bin Dahhak that the Prophet had forbidden muzaraah and permitted letting it on hire (*ijarah*)<sup>(29)</sup>.

vi) According to another Hadith, 'Whoever would not abandon sharecropping he is at war with Allah and his Prophet'<sup>(30)</sup>.

vii) Abu Daud on the authority of Abu Naim quoted Rafi Ibn Khadij as saying that he planted a piece of land and was irrigating it when the Prophet passed by and asked him: "" For whom is the cultivation done, and who owns the land?" Rafi replied: " I supply the seed and the work; the crop is divided between me and the landlord." The Prophet said: You both are committing usury. Return the land to its owner and take back your expense"<sup>(31)</sup>.

viii) Abu Dawud quoted Zaid Ibn Thabit as saying: " The Prophet prohibited share-cropping. What is share-cropping? He said: That you rent a land (for cultivation) for half or a third or quarter of the produce thereof"<sup>(32)</sup>.

ix) Abu Hurairah reported that "The Ansar requested the holy Prophet that their gardens of dates be divided between the Muhajirin and themselves. The Holy Prophet refused. Then they said that they should provide labour and we would all share in the fruits.. The Holy Prophet accepted this proposal"<sup>(33)</sup>.

x) Imam Muslim reported on the authority of Ibn Umar: " when the messenger of Allah was victorious over Khybar, he wanted to evict the Jews. They appealed to him to let them stay

---

(25) **Abu Sulaiman** (1968) as quoted by Mustafa and Askari (1988), p. 143.

(26) **Rahman** (1975), Vol. II, p. 174. as quoted by Mustafa and Askari (1988), p. 144.

(27) Abu Sulaiman as quoted by **Mustafa and Askari** (1988), p. 144.

(28) **Rahman** (1975), Vol. II, p. 177. as quoted by Mustafa and Askari (1988), p. 144.

(29) *Ibid.* (1975), Vol. II, p. 177. as quoted by Mustafa and Askari (1988), p. 144.

(30) **Abu Sulaiman** (1968) as quoted by Mustafa and Askari (1988), p. 145.

(31) *Ibid.* (1968) as quoted by Mustafa and Askari (1988), p. 145.

(32) *Ibid.* (1968) as quoted by Mustafa and Askari (1988), p. 145.

(33) **Rahman** (1975), Vol. II, pp. 197-98. as quoted by Mustafa and Askari (1988), p. 145.

on the land provided they work and get one-half of the crops. The Prophet told them: 'We shall let you do so as long as we wish.' They remained until Umar evicted them<sup>(34)</sup>.

These Ahadith apparently reveal that, at times, the Prophet had forbidden both rent and sharecropping but also sanctioned such practices at other occasions. Let us look at Ahadith i to v above which deal with land rent. According to Ahadith ii, iii and v, land rent is permitted whereas i disallows rent. However, Hadith iv, reported by Bukhari, could be conclusive which makes the saying of the Prophet in i as a recommendation rather than a requirement or obligation. A logical explanation of this position could be that a person has to spend his labour and capital to make a land cultivable. In case he feels reluctant to give away the land free of cost (which could have been preferable), he has been allowed to charge a fee or land-rent rather than leaving it uncultivated. This would make charging of rent equivalent to depreciation cost. However, as M.N. Siddiqi has mentioned, land-rent is almost always higher than the depreciation cost<sup>(35)</sup>. But this is not too difficult to explain. A portion of market determined land-rent is due to the higher market value of land. Increase in the value of land is, however, generally related to population growth or increased economic activity for which no contribution is made by the land owner. We would, therefore, suggest that in case land-rent is permitted in an Islamic country, it should be heavily taxed<sup>(36)</sup>. Similarly, an appropriate level of capital gains tax should be imposed when land is sold.

The case for general permissibility of share cropping seems to be weak as, according to two Ahadith (ix & x), it was allowed in special circumstances involving two groups of people rather than two individuals. Moreover, it is evident from Ahadith vii & viii above that the institution of share cropping was disallowed by the Prophet because it was exploitative. This also indicates that land-rent in that time was less than 1/4th or 1/3rd or 1/2 of the produce. Siddiqi (1981, p.16) points out that those who allow share cropping on pure economic ground, compare it to profit sharing. They argue that if the owner of a piece of land is entitled to the whole of net produce of his land when he is the cultivator (both on the part of the net produce that is due to his labour, and the part that is due to land), why then the same land owner cannot opt to hire a share cropper and receive that part of the produce which is due to land? This argument opens the question of appropriate share of land in the produce. It would be quite illuminating to note that in the Prophet's era, the rate of zakat on land produce was only 1/10 of the produce<sup>(37)</sup>. If we consider zakat on land as a payment for using the indestructible quality of land created by Allah, it is not difficult to see that, for the Prophet, the payment of even 1/4 th of the total produce to the land owner, who just put some labour or capital to make the piece of land cultivable, was exploitative.

On economic ground, it is generally argued that in an uncertain world share cropping could be more efficient or desirable than renting of land. It could then be argued that if rent is permitted so should be share cropping. However, as we have mentioned above, whether it is land-rent or share cropping, it should be discouraged if exploitative. It looks more plausible that, to the Prophet, it was preferable to give up land free of charge if one could not use it on

---

(34) **Abu Sulaiman** (1968) as quoted by **Mustafa** and **Askari** (1988), p. 145.

(35) **Siddiqi, M.N.**, 1981, p. 15.

(36) The goal of an Islamic state should be to discourage, if not dismantle, the institution of rent seeking and absentee landlordism.

(37) In case no artificial source of water was used in which case the rate of zakah was 1/20th of the produce.

his own and sacrifice the labour or capital he may have spent on making the land cultivable. As a second best solution, he might have allowed renting of land instead of keeping it idle and recover the cost of labour and capital. His classification of share cropping as *riba* could be seen as an indication to the fact that he may have allowed land-rent in his time because it was low and did not seem exploitative.

The two remaining issues are the permissibility and desirability of wage labor in the agricultural sector, and ceiling on land holdings. The issue of ceiling on agricultural (and urban land) is controversial among Muslim jurists and economists. Their opinion ranges from allowing limitless land holdings to making private ownership of land illegal<sup>(38)</sup>. Moreover, all of them find their position supported by *fiqh* literature. Although this topic is somewhat extraneous to the current debate, disallowing sharecropping and putting heavy tax on land-rent would not make any sense if limitless land holding and wage labor is permitted. On the other hand disallowing wage labor will be difficult as it may be needed even in those economies where land holdings are small and further reduction in farm size may make it infeasible. In our opinion, in order to attain Islamic social justice limit on landholding would be unavoidable in many Muslim economies. There could be hardly any argument against the contention that, if necessary for the general well being of the society, an Islamic state has the right to put ceiling on land ownership. The exact limit should, however, depend on the general condition of an economy. In a country which has abundant agricultural land for potential cultivators, there may not be any need to impose a ceiling. On the other hand, if there is immense pressure and tension around the prevailing land ownership structure, a limit could be enacted. This limit could be stretched only to the point beyond which further reducing of the farm size would make it infeasible.

Whether the land should be acquired after paying any compensation to the land owners should again depend on the history of land holdings. In a country like Pakistan where huge chunks of land were given by the colonial power to their supporters as reward for their support for the British raj in the subcontinent, a significant part of land holdings could be acquired without making any compensation. As a matter of fact land reforms enacted by the regimes of Ayub Khan (1959) and Zulfikar Ali Bhutto (1972) did not have any provision for compensation.

#### ***Rent of Commercial and Residential Land***

This may be one of the most difficult subjects for Islamic economic reform. People own commercial and residential land and buildings and they use them themselves and rent to others. Apparently, there does not seem to be any thing wrong about this practice as long as people own a piece of such land and they perpetually use it themselves. However, if the piece of land is in commercial or industrial use by the owner, a part of the imputed rent should be collected by the government and utilized for the benefit of the society as a whole. Similarly, if they give this land on rent or sell it, it is important to determine what part of this dealing should go to the owner of the land and what part belongs to the community. This is because a major part of the rent or capital gain is unearned and depends on the relative scarcity of land which in turn largely hinges on the rate of population growth and commercial and economic activities. In the western capitalist system this issue is by and large neglected in favor of property owners. If one

---

(38) Siddiqi, M.N. (1981), pp. 6-10 and Nomani and Rahnema (1994), pp. 99-77.



admits that an important goal of political economy of Islam is social justice then this issue cannot be overlooked. As taking over the management of residential and commercial land by any tier of government would open the avenue for corruption and source of inefficiency, the matter should be tackled through an efficient mechanism of taxing the rent which would not only divert a significant portion of the rent to its rightful recipient, the society, but still leave enough incentive to ensure efficient use of a piece of land.

### III. Labor and Wages

In the neoclassical tradition, labor is treated as yet another economic commodity which is traded in the *labor market* and the *price of labor* is determined through the interaction of demand and supply of labor. In theoretical analyses both demand and supply curves are derived through solving optimization problems of the economic agents involved. The demand for labor is a derived demand which depends on the value of marginal product of labor. An important underlying assumption made is that of diminishing marginal productivity of labor which implies a downward sloping labor demand curve. For each level of money wage there is a corresponding quantity demanded for labor i.e., there exist a functional relationship between wage rate and demand for labor. Similarly, an upward sloping aggregate supply of labor curve is an outcome of optimal allocation of time between leisure and work by the workers<sup>(39)</sup>. For each level of wages, there is a particular quantity of labor supplied. At the equilibrium wage rate, the demand and supply of labor are equal. The two curves are shown in figure 1.

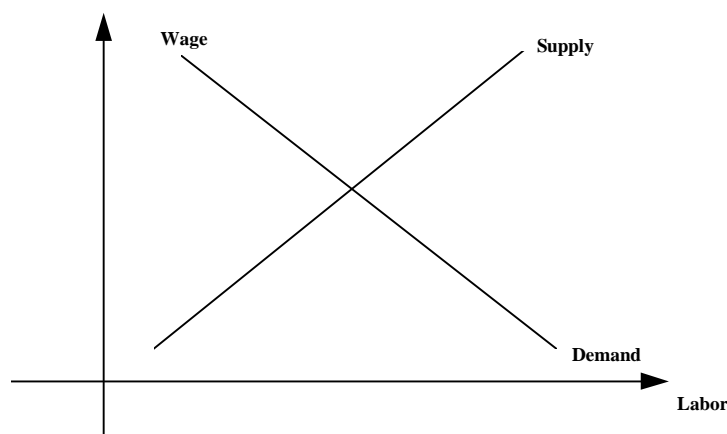

Figure 1

An important implication of this neoclassical model is that at the equilibrium, money wage is equal to the value of the output produced by the last or marginal worker employed. As all the workers of similar skills must be paid the same wage, all workers of a particular skill group get identical wage, leaving a surplus or profit for the employer<sup>(40)</sup>.

(39) At the individual level the supply of labor curve may have a backward bending segment corresponding to high level of wages. However, at the aggregate level, the overall supply of labor always increases with increase in wages. For a recent discussion of the issue see **Smith** (1994).

(40) This neoclassical theory of profit which hinges on diminishing marginal productivity of labor is a subject of criticism by **Paul Fabra** (1991) who demonstrate that profit is a reward for saving or capital and a correct theory of profit cannot depend only on diminishing returns to scale.

This neoclassical model of labor market and wage determination which still dominates the text books has been criticized by many economists belonging to different schools of thought in the western economic tradition. Before we contemplate on these criticisms, it is interesting to note that there is hardly any question raised against this model by Islamic economists. The following passage from M. Fahim Khan (1990) may reflect their general opinion:

"We do not dispute much with the theories of supply and demand of labour and capital in the conventional economic theory and can easily adopt them to explain the supply and demand of human resources and physical capital in an Islamic economy except that rental of capital goods will really be a rental and not an interest rate. Marginal productivity will determine the demand for human resources and physical capital to be employed on Ujrat basis. Supply of labour will be determined by the marginal utility of leisure to the labourer"<sup>(41)</sup>.

Some Islamic economists have suggested to merge labor with entrepreneurial input<sup>(42)</sup>. On the other hand Uzair argues for merging enterprise with capital<sup>(43)</sup>. However, we hope that the arguments given in the next two sections will convincingly show the distinct role of entrepreneurial input in the production process. There does not seem to be any reason to change the traditional definition of labor which means human input employed by someone to perform a well specified but non-entrepreneurial job. Furthermore, labor is normally paid a fixed wage but if both sides agree, part or whole of its remuneration could be related to profits of the enterprise.

There are several objections to the neoclassical formulation of labor market and wage determination<sup>(44)</sup>. One set of arguments is advanced by the proponents of the institutionalist school in the general context of a capitalist market economy. According to this school of thought, the central economic problem is the organization and control of the economy. The distribution of income is not a function of neutral 'natural' markets but the exercise of the power in the market and especially in the institutions which form and operate through the market. They argue that the performance of labor market reflects the circumstance that the demand for labor is much more a function of final output (and effective demand for same) than of the relative price of labor. They do not deny the fact that labor can price itself out of the market or engender capital substitutions. They have studied the formations of labor market and the actions of participants therein to shape both market structure and performance to their desires, in part through influencing public opinion and government policy (protective labor market and labor relations legislation). Central to their studies have been the analyses of labor markets as arena of mutual coercion, labor unions and collective bargaining<sup>(45)</sup>.

---

(41) Khan, M.F. (1990) pp. 38-39.

(42) Siddiqi, M.N. (1981, p. 58) and Mustafa and Askari (1988, p. 96).

(43) Siddiqi, M.N. (1981), p. 57.

(44) We overlook the Marxian view on this issue which relies on Marx's notion of labor theory of value and the appropriation of part of (surplus value) by their employers.

(45) Samuels, W.J., "Institutional Economics" in Greenaway, et. al. (1991).

The Post Keynesian analysis of the labor *sector* has two interrelated elements. The first is that the exchange of labor services and the determination of wages do not take place in a *market* as that term is usually understood. Wages are often set through collective bargaining. But even when collective bargaining does not take place, the influences at work are rather similar. As Routh (1980) argues, it is a mistake to imagine that there is a sharp division between the unionized and un-unionized workers, for trade unions cannot do more than institutionalize and direct drives and aspirations that are already present in the individual worker<sup>(46)</sup>. The second element is that bargaining is made about money wage and not the real wage. However, following Keynes, they believe that prices move rapidly to ensure equality between the real wage and the marginal productivity of labor. In a Kaleckian approach, the real wage is set by the mark up of prices over costs (including wages). The common feature between this and the Post Keynesian approach is the idea that prices are determined after nominal wages are set and that workers, individually or collectively do not influence real wages. However, the Post Keynesian share the view held by the neo-classical school that at the margin, the wage rate is equal to the value of the product associated with the marginal labor. Any variation in the money wage will be rapidly offset by a corresponding variation in the price level, leaving the real wage unchanged<sup>(47)</sup>.

A more fundamental critique of neoclassical notion of demand and supply curve for labor comes from a group of economists who have criticized neoclassical theory on the issue at hand by reinterpreting classical economists (or pointing out the inaccurate representation of that school by the neoclassical economists) especially Adam Smith and David Ricardo<sup>(48)</sup>. Like Post Keynesians, they also believe that the nature of demand and supply of labor is different from other *commodities*. According to them, neoclassical assumption of diminishing marginal productivity of labor is an inappropriate use of Ricardo's theory of land rent in agriculture. But even if one agrees with the assumption of diminishing marginal productivity of labor, the marginal worker, and hence all the workers in his class, are never paid a wage equal to the value of marginal product of the last worker at the equilibrium. Furthermore, the demand for labor is not *functionally* related to the wage rate. Unlike other commodities, the demand for labor, according to them, is a *quantity* and not a curve. The demand for goods and services, and the technology which does not change in the short run, determines the demand for labor in the capitalist sector of the economy<sup>(49)</sup>. Thus, at a given point demand for labor is equal to the existing level of employment plus vacancies<sup>(50)</sup>. What constrains an enterprise to expand is not diminishing productivity of labour (and hence the need to decrease wage rate for further employment) but lack of clientele or financial resources or both<sup>(51)</sup>.

---

(46) Routh, G., as mentioned in Sawyer (1991), p. 194.

(47) Sawyer, Malcolm C., "Post Keynesian Macroeconomics" in Greenway *et. al.* (1991), p. 194.

(48) Two extremely interesting recent books on this subject are Fabra (1991) and Stirati (1994)

(49) This follows the absence of direct and indirect substitution between factors with changes in distribution (Stirati, p. 5). In principle, Ricardo did not rule out the possibility that innovation and use of machine, which may have been stimulated by higher wage rate, can decrease level of employment. However, in practice, according to Ricardo, the fund for machinery would often be acquired not by diverting existing capital from its previous employments, but by investing net savings in its acquisition. Thus its introduction would often reduce the rate of growth of employment, but not its level., as would instead be required for the construction of a decreasing demand schedule for labor (Stirati (1994), p. 190).

(50) Stirati (1994), p. 7.

(51) Fabra (1991), p. 50.

This last group of economists have also emphasized the classical concept of a minimum level of wage (that which can vary through time and space and not necessarily the subsistence level) below which wage rate cannot be pushed down even when unemployment exists. This is close to the Keynesian notion that money wages are inflexible downward. However, while Keynes emphasized the existence of powerful trade unions and their concern for money wages,<sup>(52)</sup> Smith and Ricardo considered cultural reasons and real wages<sup>(53)</sup>.

We now make an attempt to synthesize the arguments given so far. It would be appropriate to assume that an employer can hire a worker only if his contribution at the margin is *higher* than the wage paid to him. But it is not necessarily true that workers are continuously hired to the point where the contribution of the marginal worker reaches existing wage rate. The number of workers hired depends largely on level of planned output which in turn depends on expected sales, the existing production capacity and the related technology. In many cases these other factors, and not the wage rate, may dictate the total labor requirement. Indeed, production would not be feasible if, given other expenses (i.e., cost of machine, raw material, rent, etc.), the total wage bill is so high that it does not leave a reasonable expected rate of profit. On the other hand, it is more likely that, for given level of output prices, effective demand for goods and services, technology and productive capacity, all the different types of workers required are hired for as little as possible. The demand for labor with respect to wage rate could thus be of the shape shown in Figure 2a.

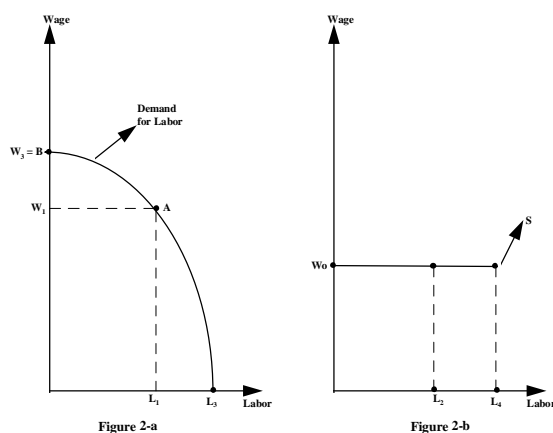

Figure 2

(52) Real wages, in the Keynesian analysis is not or cannot be explicitly determined during the labor management negotiations although the workers do form expectation about future level of prices.

(53) In their scheme, if the price of wage goods increased, it would necessitate a corresponding increase in money wages so that the workers can afford to buy a consumer basket constituted by the prevailing custom and culture.

The demand for labor schedule  $BAL_3$  could be divided into two parts; BA and  $AL_3$ . For given level of general prices, aggregate demand, financial resources, and productive capacity, demand for labor vanishes with money wage rate  $W_3$  and above. As wage rate decreases from  $W_3$ , demand for labor keeps increasing steadily till  $L_1$  labor is employed. The wage rate range of  $W_1W_3$  is high and labor employment is mainly constrained by wage rate. This could be classified as the *neoclassical range*. Below  $W_1$ , however, wage rate is not the binding variable for further employment of labor. A decline in wage rate in this range may invoke only an insignificant increase in demand for labor. This part of the demand curve could be labelled as the *classical range*<sup>(54)</sup>. Other things unchanged, with higher demand for goods and services in the economy, the  $BAL_3$  curve shifts to the right. On the other hand, the supply of labor is almost perfectly elastic until a great fraction of the labor force is already employed (Figure 2b). If demand for labor is such that  $L_2$  labor is currently employed then  $L_2L_4$  is the labor force unemployed or self employed with an earning less than or equal to what they could earn through wage. There are workers beyond  $L_4$  who are self employed or voluntarily unemployed at the going wage rate who would increasingly join the labor force if the market wage rate keeps moving upward from  $W_0$ .

Given the demand for labor, the position of the supply curve will determine the wage rate paid to the labor. In a labor scarce country, workers may be able to push up the supply curve to  $S_1$  extracting the maximum possible rate of remuneration  $W_2$  from the employers (Figure 3a). Given the level of demand, an attempt to further push up the wage rate, for example, by unionized workers will lead to increase in unemployment, all other things being unchanged. Employment could then be increased either by pushing the demand curve to the right (for example, by increase in output prices or giving an export rebate) or if the unemployed workers accept a lower wage rate. However, if non of these two things happen and all other variables remain unchanged, prolonged unemployment may eventually force the workers to accept a lower money wage rate<sup>(55)</sup>.

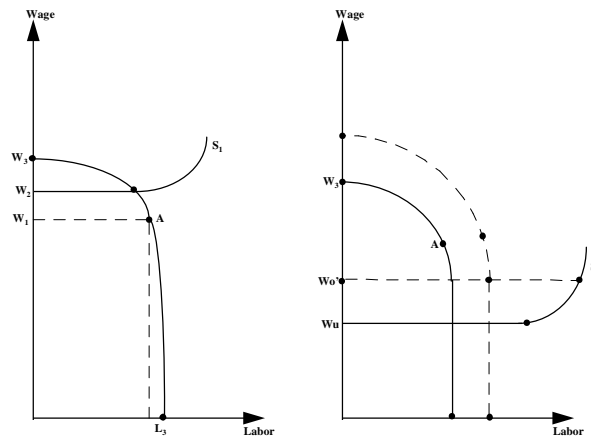

Figure 3-a

Figure 3-b

Figure 3

- (54) **Stirati** (1994, page 5) has argued that for classical economists, demand for labor at a point in time was a quantity and not a curve.
- (55) Keynes emphasized that the workers normally resist any cut in nominal wage rate although they may allow a decline in real wages brought about through increase in general price level which leaves the relative wages of different groups of workers unchanged.

Like other less developed or developing countries a number of Muslim countries have relatively abundant supply of labor. In these economies the position of the supply curve may be that of  $S_2$  and the market wage rate  $W_0'$  (Figure 3b). In order to increase level of employment towards  $L_4$ , policies could be adopted to push the demand for labor curve right ward e.g., by attracting foreign direct investment, facilitating exports, etc. At the same time, however, government can encourage gradual and small increments in money wages (more than any increase in prices) towards  $W_0'$  and beyond without any fear of increasing unemployment.

If the demand curve is  $BAL_3$ , and a government legislation fixes minimum wage above  $W_0$  but below  $W_1$ , provided that the increase is not too steep, the decrease in the level of employment may be negligible. The obliteration of existing profit level may provoke the producers to push up their prices to regain their previous levels of profits which has a potential to trigger inflationary pressure in the economy. However, if the government can control the supply of money, prices of all goods in the economy cannot be increased. In the long run, if the government remains firm at the back of the labor force and money supply is kept constant, resources would be shifted from the production of non wage goods to wage goods eradicating the pressure on prices of the latter. Appropriate fiscal policy can also enhance the production of wage goods. Nevertheless, it would undoubtedly create a tension in the economy affecting the rate of growth of new investment before full employment is achieved. To avoid confrontation and contempt for each other attention should be given to policies which would, on the one hand increase the demand for labor, and allow small increments in wage rate on the other.

Once the demand curve has been pushed to  $D_2$ , and employment level approaches  $L_4$ , a credible and resolute stand by the government will be required to make the employers accept a relatively lower level of profits. Siddiqui (1994) has emphasized the presence of a reservoir of potential entrepreneurs in an Islamic financial system without the institution of interest and collateral. These potential entrepreneurs, without substantial amount of wealth, would be ready to take up new businesses involved in the production of wage goods. Moreover, their presence would also weaken the traditional political power of the existing producers. It is, therefore, possible for a prudent government under an Islamic economic system to get an appropriate share of income for the workers through the market forces.

The above analysis is in no way an attempt to ridicule the recipient of profits in the existing capitalist economies which include most Muslim countries. Out of pure human instincts, every economic agent in the production process has a tendency to extract as much as he can from others and pay as little as possible. It is the responsibility of Muslim economists to devise a system which influences the behavior of economic agents in a desirable way. As we underscore in the next two sections, far from making the entrepreneurial class a target of retribution, an Islamic economic system would assign a leading role to the entrepreneurs. While they would be allowed (apart from the investors) to strive for a reasonable share in the business profits, their responsibility would include defending the genuine rights of the working class.

#### IV. Capital and Interest

Among all the factors, the issue of capital and its reward, interest, has been the most complex. In conventional economics capital means physical capital, and interest is regarded as payment of *rent* to physical capital<sup>(56)</sup>. However, interest is not referred to as per machine or per building but as a rate per dollar. A conventional explanation for this is provided by the impossibility to account for all types of capital goods and their separate rentals. It is easier to consider all capital goods in money value and regard their rental as a rate per dollar value of capital goods<sup>(57)</sup>. As Baumol and Blinder claim, interest is the payment for the use of funds employed in the production of capital; it is measured as a percent per year of the value of the funds tied up in the capital<sup>(58)</sup>.

Interest, however, is not referred only as rent to capital which, according to Fisher, depends on the investment opportunity rate. On the other side of the coin, it is seen as a payment to the lenders for their postponement of the present consumption until at a future date. According to Fisher, the more impatient the consumer is for present consumption, the higher must be the reward or compensation for the postponement of present consumption. In equilibrium these two rates are equal<sup>(59)</sup>. Furthermore, because the borrower in a consumer loan situation is able to consume something earlier than later, he can be asked to pay interest as he is also supposed to prefer present to future consumption and expects a higher income in future<sup>(60)</sup>. It is, therefore, not unethical or unjustified to charge interest even if the loan is made for consumption purpose.

This makes the distinction between usury and interest irrelevant. Although it should be admitted that in most cases interest is paid out of business profits, it is never linked to the profits of the businesses. Interest has to be paid irrespective of the levels of profit. Interest cannot be comfortably linked to the risk as it is paid even on seemingly non risk assets such as treasury bills and government securities. In the context of western tradition, it is more appropriate to regard interest primarily as a reward for saving. Any differences in the rates of interest could then be linked to the levels of risk and period of loan.

Perhaps a more suitable definition of capital in the context of capitalism would be one provided by David Ricardo. "Capital is that part of the wealth of a country which is employed in production, and consists of food, clothing, tools, raw materials, machinery, etc. necessary to give effect to labor"<sup>(61)</sup>. According to Paul Fabra, this definition of capital which excludes money could be construed as a logical consequence of Ricardo's opting to reason in macro economic terms and a theoretical universe without money. At the level of enterprise, it would be legitimate to include monetary holdings in capital because, they represent enterprise's entitlement to a certain quantity of real goods, existing on the market, which will make up its fixed capital and circulating capital<sup>(62)</sup>. In the contemporary capitalist system, therefore, this definition would also include money set aside for wages (which is spent on food, clothing and other expenses incurred by the labor including any thing above subsistence which he saves), raw materials and other services.

---

(56) Samuelson (1980), p. 557.

(57) Khan, M.F., (1990, p. 27).

(58) Baumol and Blinder (1991), p. 745.

(59) Fisher in Oser and Brue (1988), p. 303-4.

(60) Bohm Bawerk in Oser and Brue (1988), p. 246.

(61) Paul Fabra (1991), p. 15.

(62) *Ibid.* (1991), pp. 16-17.

In Ricardo's vocabulary, and for classical economists in general, profit was a return to capital and interest was paid out of profit to the providers of monetary resources in the production process. They never addressed the following problem: Should interest be paid even if there is no profit or there is a loss? The reason was obvious; an affirmative answer would require a separate theory of interest whereas a negative one would go against a practice which had become quite common and acceptable by that time. An attempt was made by Nassau Senior towards the end of the classical era to link interest to the sacrifice made by the providers of funds. This was, however, contested and ridiculed by Marx and other socialist writers. It was first Bohm Bawerk and later Irving Fisher who provided more sophisticated theories of interest.

Because of failure of perspective, Bohm Bawerk claimed, people systematically underestimate future wants, and the goods which are to satisfy them. This was the only *irrationality* Bohm Bawerk introduced into his economic man. People underestimate future needs because they have defective imaginations, limited will power to resist present extravagance, and because they know that life is short and uncertain and therefore they feel it is better to enjoy life today than to sacrifice for the future<sup>(63)</sup>. Another subjective basis for interest, in Bohm Bawerk's theory, which again focuses on consumption was the idea that people expect higher income in the future and therefore are willing to borrow now and pay more later. The only objective explanation of interest was provided by observing the fact that use of capital allows round about production process to produce more final goods<sup>(64)</sup>.

According to Fisher, the rate of interest is determined by two factors: a) the investment opportunity rate which determines the demand for loanable funds, and b) the impatience rate which determines the supply of loanable funds. As more and more investment is made, the expected rate of return on further investment declines. On the other hand people are generally impatient to spend their money on current goods compared to future consumption. It is, therefore, important to compensate the savers or providers of funds for postponing their consumption. This rate of compensation must increase as they are asked to provide more and more funds. The supply of funds is, therefore, positively related to rate of compensation (interest rate) and the demand inversely related to interest rate as investment opportunity rate declines with more and more investment<sup>(65)</sup>. The equilibrium rate of interest is, therefore, one which brings the impatience rate and the investment opportunity rate to equality<sup>(66)</sup>.

In Keynes' scheme, the rate of interest at any time, is the reward for parting with liquidity, and a measure of the unwillingness of those who possess money to part with their liquid control over it. According to him, the rate of interest is not the 'price' which brings into equilibrium the demand for resources to invest with the readiness to abstain from present consumption. It is the 'price' which equilibrates the desire to hold wealth in the form of cash with the available quantity of cash<sup>(67)</sup>. The rate of interest is determined by the liquidity preference which gives demand for money function. Given the supply of money, the equilibrium rate of interest is one at which the demand for and supply of money are equal<sup>(68)</sup>.

---

(63) Oser and Brue (1988), p. 246.

(64) *Ibid.*

(65) In Keynes' terminology, the investment opportunity rate is same as marginal efficiency of capital.

(66) Oser and Brue (1988), p. 304.

(67) Keynes (1936), *The General Theory*, pp. 166-67.

(68) Oser and Brue (1988), p. 422.



### **An Islamic View**

We start this section by asking a fundamental question about consumption and production loan. Does Islam prohibit any payment on all types of consumption and production loans? And if so, what could be the underlying rationale for such prohibition. It is reasonable and important to admit the fact that whenever a person gives any type of loan (*not sadaqa*) to any one, it does have an element of sacrifice in the following three senses: (i) there is anxiety whether the loan would be paid back or not (ii) a possibility of missing a profitable opportunity during the loan period and (iii) the loaned amount may be needed for important and urgent personal consumption. However, in order to promote brotherhood and fraternity among human beings, Islam prohibits charging of any interest on consumption loan. But to deny the reality that, in general, there is some sacrifice made by the lender would be wrong. Muslims are asked to make that sacrifice. However, there could be many cases in which people do feel good after giving loans to friends and relatives or to fellow human beings in distress even when they understand that there is a possibility of default. Islam *encourages* to give sadaqah and Qarde Hasan. It also asks Muslims to give more time to the borrowers in case he/she is having problem in paying back --- all to promote humanity and a reward in the hereafter. The least desirable thing for a Muslim who has been approached by a fellow human being for consumption loan is to make an excuse gently and politely. But to give consumption loan and then ask for an increment over the original is unquestionably prohibited.

A possible objection to this assertion could be the existence of inflation in a modern monetized economy. This raises several issues: Can there be inflation (sustained increase in general price level) without increasing the supply of money beyond certain limit? If no, should an Islamic economic system then permit occurrence of inflation through its monetary policy (changes in stock of money)? If yes, then under what circumstances? Shamim Siddiqui (1994) addresses these issues and concludes that it is possible to avoid the occurrence of inflation under an Islamic economic system. However, even if we admit, for the sake of argument, that inflation is a permanent feature of any modern economic system (Islamic or otherwise) and that it is not purely a monetary phenomenon, it only allows a case for indexing consumption loans to make adjustment for inflation. The main problem with indexing even consumption loans is that it makes inflation acceptable and gives a freer hand to the government to create money. It encourages her to become prodigal and avoid taking politically harder decisions to generate financial resources.

In case of production loan, the lender is allowed to accept a fraction of the profit if he also agrees to share the losses. The rationale is again based on the human fraternity and brotherhood. In Islamic system of humane relationship and social justice, it is unethical on part of some of the providers of the business funds to ask for fixed interest irrespective of the outcome of the business. On the other hand, it would be unjust on part of the borrower to pay only a predetermined (small) rate of interest even if he is able to make a big fortune out of the business. Similarly, it is unjust to pay the lender a nominal rate of fixed interest when the rate of inflation is higher than this rate and the borrower is able to make a substantial profit. This is the case in Pakistan and many other developing countries where borrowing from commercial banks has become a cruel source of exploitation of bank depositors<sup>(69)</sup>.

---

(69) The above cannot, however, be an analogy for disapproving fixed payment to labor. It is not too difficult to see through the difference. Labor is generally paid wage as current income for current consumption for living. There is nothing wrong if a well to do labor risks all his labor for a share in profit, or some workers agree to link part of their income to uncertain performance of the business entity. But to expect that workers in general should agree to exchange their labor totally for an uncertain income will be unjust.

It could be admitted that some individuals in the society may not have any other resources to earn a living (an old or disabled person) but a small amount of savings which they would not want to put to risk. Some special arrangement could be made for those individuals such as creation of a welfare fund by each business using their savings in the production process, which can dispense necessary relief to them in case of a business loss. Alternatively, their savings could be put under some government department or prudent private agencies, indirectly controlled by the government, who can efficiently manage diversified portfolio even if that leads to a relatively low level of returns. But on the pretext of presence of such individuals (e.g., old or disabled persons), a general permissibility of institution of business interest goes against the Islamic sense of social justice.

Another issue we would like to raise at this point is that it is immaterial whether a business loan is offered in terms of money or physical capital. In this regard, the argument put forward by Mustafa and Askari (pp. 99-100) needs reconsideration. They claim that money could not be treated as capital and qualify for a return unless it is converted into physical capital. This argument seems to be the result of treating capital in the neoclassical sense where capital means physical capital but, in order to lump together all types of physical capital, both their value and return (interest) are converted into monetary units. In this scheme, until money is converted into physical capital, it does not deserve any return. Money is, however, needed by a business to pay wages, buy raw materials, machines and equipments, rent or buy a building or a piece of land, etc.

We would, therefore, suggest to make the following two distinctions: First, between *physical capital* and *capital*, which are not *always* equal. Second, between capital in the macroeconomic terms and capital at the microeconomic or enterprise level. The definition of capital given by Samuelson and Nordhaus (see section 1 above) is correct in the macroeconomic sense. They define capital stock as durable goods produced by the economy in order to produce yet another goods. In this macroeconomic sense, capital is always physical capital and consists of buildings, machines, tools, roads, computers, etc. In the macroeconomic framework money is only a claim on given resources in the economy. As all the resources in the economy used in the production process are counted for by land, labor, entrepreneurial input, physical capital and raw materials, money is left out in the macro scheme. At the enterprise level, however, physical capital is only a part of capital which, in addition to physical capital, also includes monetary funds used to buy additional physical capital, pay wages (food and clothing in Ricardo's vocabulary), buy raw materials (such as milk and wheat for an agro based enterprise, iron ore for a steel mill or cotton for a textile mill) or pay rent for a building or a piece of land. The people who provide resources to an enterprise in monetary units to buy physical capital, pay wages, purchase raw materials, rent or buy a piece of land, -- are all *investors* (or *capitalists*). In an Islamic economic system, without the institution of interest, they are all eligible to claim a share in the profits of the enterprise. Also, in case of a loss, they are all responsible to share the loss of the enterprise.

Of course, a person can lend his physical capital (for example, a machine) to an enterprise for a share in profit or fixed positive amount for a certain period of time. As he provides physical capital, he should be classified as capitalist.

## V. Entrepreneurship

According to the classical economists, an entrepreneur was a person (or persons) who decided what goods to produce and brought factors of production together to produce them.<sup>(70)</sup> In the classical sense, an entrepreneur was, therefore, an organizer and a risk taker. In many cases he used to invest his own funds for his business undertakings and for that matter he was also a capitalist. Although, unlike the Austrian school, they did not place the entrepreneur at the center stage of the laissez fair market economy, they recognized the importance of profit for investment, growth and prosperity.

As far as the neoclassical school is concerned, in a recent book Parker and Stead (1991) point out its inadequate emphasis given to the role of entrepreneurship. The reason for this deficiency, according to them, is that in neoclassical economics, the process by which market economies adjust and change is neglected in favor of an analysis which focuses upon market equilibria. In particular, in the neoclassical system there is no real analysis of motivation -- too 'just happen' -- nor is there much attention to supply of entrepreneurship; where do entrepreneurs come from, what motivates them and what is the entrepreneurial function?" The neoclassical economics has no theory of profit either. There are rather number of insights relating profit to the remuneration of abstinence, compensation for risk taking and wages of superintendence, which leave unclear the difference between profit, managerial payments and interest on capital<sup>(71)</sup>.

The adherents of the Austrian school who claim to be the true heirs of the classical economic doctrine, dispute the main stream neoclassical notion of market equilibrium and an entrepreneur who reacts to circumstances of disequilibrium in a world of perfect information involving little or no real choice<sup>(72)</sup>. Furthermore, even when the problems of imperfect competition and information are introduced in the neoclassical models, their approach is still based on the idea that human behavior is amenable to objective assessment. The Austrians argue that people differ in both the amount of information and their ability to react to it. As economic knowledge is subjective there is no objective solution to determine a market equilibrium<sup>(73)</sup>. The Austrian school stresses on *market process* over neoclassical notion of market equilibrium. The prime mover of this market process is the entrepreneur who not only reacts and capitalizes on existing disequilibrium in the market but also causes the disequilibrium through innovation.

Even if one agrees with the Austrians on their emphasis on the central role of entrepreneurs in the market economy, the issue of defining who is an entrepreneur remains complicated. This is due to the complex nature of a modern corporation where, by and large, the ownership is separated from the management. All business decisions on day to day affairs are made by the managers (executives) but any major and important decisions on new products or new methods of production have to be approved by the board of directors. In some corporations, a dominant share holder is able to appoint himself or his nominated one to the post of chief executive of the corporation. Furthermore, as most boards of directors are also

---

(70) **Harvey** (1988), p. 75.

(71) **Parker** and **Stead** (1991), p. 85.

(72) *Ibid.*, Chapter 5.

(73) *Ibid.*, p. 97.

chaired by the chief executives, in such cases, the dominant share holder keeps the corporation under his firm control<sup>(74)</sup>. But most corporations are now run by chief executives who do not own any significant portion of the total shares of the company. Moreover, in most cases, they not only preside the boards of directors but are considerably influential in appointing other members of the boards.

Another aspect of the issue is related to the remuneration of the top managers in their current jobs which is now, at least partially, linked to their companies' performance. Their *future worth* is, therefore, closely related to their current performance. Thus, whenever they make a key decision about a new product or a new method of production, they do put at risk part of their current income and future worth. It does not seem to be too unrealistic to claim that the top executives of modern corporations should be included among entrepreneurs even if part or whole of their current income are fixed and predetermined.

Two other important groups in the context of modern corporations are share holders who individually hold a very small fraction of total stock of a company but collectively carry a significant part of the same and, institutions (such as banks and pension funds) that hold big chunks of the shares of a firm. They may not be directly involved in making any decision but the fact that the share holders can sell their stocks if dissatisfied with the performance of the firm, affecting share prices, has an important bearing on the decision of both the managers and the board of directors. Similarly, the big institutions carrying a significant portion of total share of a company have not only power to affect the share prices but can also influence the composition of the board of directors. However, unless the company drifts significantly from a profit making path, neither the small share holders nor the big institutions exercise their options. All important decisions on output, cost and employment is made by the top managers. It is, therefore, inappropriate to classify stock holders, big or small, as entrepreneurs. Indeed, they do take the ultimate risk of the business and for that they must have a share in the profit of the company. But performing only the function of risk taking does not make them entrepreneurs.

It seems that there is a general lack of clarity among the contemporary Islamic economists regarding the role played by entrepreneurs in a capitalist market economy and the suggested function of this important factor under an Islamic market economy. Their suggestions range from treating entrepreneur as labor to merging it with capital. A definition of entrepreneur provided by Fahim Khan needs close scrutiny. According to him:

"Entrepreneurship, in our framework, has to perform the following functions: a) Making a decision whether or not to participate in or initiate a particular productive activity. b) Be willing to bear the risks associated with it.

Thus, in our framework, an entrepreneur does not have to be a special man. If he can simply visualize a productive profitable venture, can take a decision to initiate it and is willing to subject the resources at his command to bear the risks, if any, associated with this project, he becomes an entrepreneur. He may not be having the special

---

(74) A recent survey of corporate governance by the weekly *Economist*, London (January 29, 1994), examines the nature of corporate control in some leading capitalist countries. It also describes the shareholders' contempt for the role of executives. Another excellent reference to corporate control and power is **Herman** (1981).

organizational capabilities as highlighted in economic literature. It is assumed that organizational capabilities can be hired by offering appropriate Ujrat to the managers or executives capable of doing the job<sup>(75)</sup>.

and

"No human resource can become entrepreneurial simply on the basis of decision making function. Some resources have to be offered to bear the risk. The share in the profits of the project will be dependent upon the resources that are invested to bear the risk<sup>(76)</sup>.

Finally,

In fact, risk bearing is the necessary and sufficient condition to define an entrepreneur. Any resources willing to bear the risks of a project implicitly are making a decision to initiate or participate in a project. The distinction between decision making and risk bearing has been made to highlight the nature of human resources which may make a decision without subjecting themselves to risk bearing<sup>(77)</sup>.

Several points are worth consideration. It is not clear as to what is the definition of an entrepreneur? At first it is said that an entrepreneur makes the decision about a productive activity and he also takes the risks but then it is asserted that taking risk is a necessary and sufficient condition to qualify for an entrepreneur. According to this later definition, a person who is one of the sleeping partners of a small firm or if he just holds some common stocks of a company, is an entrepreneur because he shares the risks of the business. However, as we have suggested in section 4, sharing the risk of the business should only make him eligible to claim a share in the profits. An entrepreneur is a person who makes major business decisions such as introduction of a new business, new product or new method of production. As the proponents of the Austrian school have emphasized, an entrepreneur does not only visualize profit opportunities due to existing disequilibrium in a market, but also creates profit opportunities through innovation in products or costs. In a world mired with uncertainty and competition, this is in no way a trivial job.

It should not matter whether or not an entrepreneur presents, or asked to present, his own labor or financial resources to share the risk of the business concerned. He should be allowed to provide only his entrepreneurial abilities (if he so desires) and could also be permitted to sk for a predetermined fixed remuneration (again, if he so desires). It should also not matter if we label this fixed remuneration as wage, same as a worker's remuneration could be classified as profit if he agrees to share the profits or loss of the business instead of receiving a predetermined fixed wage. A factor of production should be primarily defined according the nature of its contribution to the production process rather than with reference to its mode of remuneration.

---

(75) **Khan** (1990), p. 30.

(76) *Ibid.*, p. 30.

(77) *Ibid.*, end note No. 2, p. 44.

Before the emergence of the modern corporate sector, a typical entrepreneur also used to be a proprietor or a partner in a business and thus performed both the functions of decision making and risk taking. In every capitalist market economy, a vast majority of entrepreneurs still belong to this category. However, in a modern corporation, where ownership is separated from decisions making, the nature of decision making has become quite complex. While most operational decisions of a day to day nature are made by the fixed salaried lower grade managers, major decisions such as introducing a new product or a new method of production are decided by top managers with the approval of the board of directors which include representatives of the stock holders (owners). These top managers are increasingly asked to hold a stake in the performance of the firm by accepting a significant part of their remuneration in terms of company shares<sup>(78)</sup>. It has been argued that many top corporate managers may have, apart from a reasonable rate of profits, some additional goals on their agenda such as augmenting the size of the corporation which increases their standing and future worth in the market for entrepreneurs. Furthermore, the additional goals are generally realized at the cost of relatively lower corporate profits. It is expected that asking the top managers to have a stake in the profits of the company would mould their behavior and set off their goals. But their function of making important business decisions in a world of uncertainty and increasing competition would remain unchanged.

As the future worth of top managers, even when it is materialized in terms of predetermined fixed remuneration, is affected by their current record, they do take an implicit risk in making major decisions. It could thus be claimed that an entrepreneur is one who envisions some profit opportunities and makes major decisions of production activities and at least takes an *indirect* risk by putting his own future worth at stake. However, because it is not *necessary* for him to take a direct risk of the business, *direct* risk taking should not be a necessary condition to become an entrepreneur. All those individuals and institutions who only provide funds or capital (in its broader sense as mentioned in section 4) for the business should be classified as *investors* such as stock holders of a corporation or sleeping partners of a limited firm. They share the risk of the businesses and its profits.

The job of an entrepreneur, both as a proprietor and a top manager is very important. Most people who do possess financial resources or ordinary managerial talents, avoid to take entrepreneurial challenges. This is true for a capitalist market economy and it should be correct for an Islamic market economy. We would rather go one step further to assert that under an Islamic social system with an Islamic market economy, entrepreneurs may have to be given even a higher importance and enhanced "social" status. In the capitalist market economy, motives of profit and higher expected salary in the future drive their dynamism to avenues of new business, products and productive methods. In an Islamic market economy all the investments would be made on a profit and loss sharing basis, and the plight of the workers and distributive justice would be an important part of the *economic game*. This would require the entrepreneurs, being the top executives of a firm or company, to be more honest and more sympathetic to the plight of the workers. It is expected that the eradication of the institution of interest and collateral would substantially increase the potential number of entrepreneurs in an Islamic economic and financial system. A higher social status and prospect of good salary and/or a share in the fortune of the business can attract competent as well as honest persons of

---

(78) Please see, "A Survey of Corporate Governance" in *The Economist*, London (January 29, 1994).

a Muslim society to this profession. It can be advisable to set up autonomous bodies under federal and/or provincial governments who can issue (required) certificates to the potential entrepreneurs after giving them necessary briefing/training about their important role in the economy and society at large. They can also be asked to take oath to safeguard the interests of the workers and investors. The basic purpose of this exercise should be to have yet another way to enhance the social status of entrepreneurs and to remind them of the important position they would hold in a Muslim society. Market mechanisms, as we have discussed above in the context of capitalist economies, would still be required to mould their behavior to achieve a desirable set of goals.

## **VI. Conclusion**

The deliberations in different sections of this paper clearly show the need to keep the conventional categorization of factors of production into four broad groups (i.e., land, labor, capital and entrepreneurship) under political economy of Islam. However, we define entrepreneur as one who makes major business decisions and at least takes some indirect risk of the business. An entrepreneur may or may not be one of the owners of an enterprise.

The issue of returns to different factors of production under an Islamic system is very important. While land could be owned by private individuals, an Islamic government can determine the maximum size of land holdings for a Muslim country depending on relative abundance of cultivable land. Land thus owned could be cultivated by themselves or by engaging wage workers. Our discussion in section 2 has also shown that a case for land-rent could be made provided that the land-rent could be kept low or the government takes away a part of the land-rent to be spent on the general welfare of the masses. The argument for share cropping comes out to be even weaker unless the land owners could be made to accept a very small share of the output.

A part of rent of a residential or commercial structure includes the rent of the land on which it stands. This land-rent increases with increase in population or economic activities without any contribution of the land owner. It is, therefore, suggested that a significant part of the rent of buildings should be taxed away.

Labor would normally be paid a fixed nominal wage. We have shown how the rate of remuneration of this factor of production could be affected by non market forces. Depending on the level of employment and level of wages, there is a role for the government to help the workers get a fair share of the pie.

Owners of monetary and physical capital can invest in an enterprise and claim a share in the profits. The owners of physical capital can also offer their capital on rent (or more precisely quasi-rent) and may make a profit over the entire life of the capital.

An owner entrepreneur automatically shares the risk of the business. However, whether an owner or not, he can ask for fixed remuneration for his entrepreneurial input. Whether that is also accepted by the investors or capitalists (i.e., owners or share holders) would be a different matter. Similarly, the investors may insist that an entrepreneur takes direct risk of the business.

## References

- Abu Sulayman, Abdul Hamid Ahmad (1968)** "The Theory of the Economics of Islam," in: *Contemporary Aspects of Economic Thinking in Islam*, Proceedings of the Third East Coast Regional Conference of the Muslim Student's Association of the US and Canada, 1968, American Trust Publications, 2nd printing, 1976.
- Barrow, John M., and Lynch, Gerald J. (1993)** *Economics*, Third edition, Richard D. Irwing Inc., Homewood, Illinois, USA.
- Baumol, William J., and Blinder, Alan S. (1991)** *Economics: Principles and Policy*, Fifth edition, Harcourt Brace Jovanovich Inc., New York.
- Behdad, Sohrab (1992)** "Property Rights and Islamic Economic Approaches", in: **Jomo, K.S.**, *Islamic Economic Alternatives*, Macmillan Academic and Professional Limited, London.
- Bohm-Bawerk, Eugen Von (1891)** *The Positive Theory of Interest*, (Translated by William Smart), London, Macmillan.
- Deane, Phyllis (1978)** *The Evolution of Economic Ideas*, Cambridge University Press.
- The Economist (Jan, 29, 1994)** "A Survey of Corporate Governance", London.
- Fabra, Paul (1991)** "Capital For Profit", Rowman & Littlefield Publishers, USA.
- Fisher, I. (1930)** *The Theory of Interest*, New York, Macmillan.
- Greenaway, David; Bleaney, Michael and Stewart, Ian M.T. (editors) (1991)** *Companion to Contemporary Economic Thought*, London and New York, Routledge.
- Harvey, Jack (1988)** *Modern Economics*, fifth edition, London, Macmillan Education.
- Herman, Edward S. (1981)** *Corporate Control, Corporate Power*, New York, Cambridge University Press.
- Hunt, E.K., and Sherman, H.J. (1975)** *Economics: An Introduction to Traditional and Radical Views*, Second Edition, New York: Harper & Row.
- Keynes, J.M. (1936)** *The General Theory of Employment, Interest and Money*. London, Macmillan.
- Khan, M. Fahim (1990)** Factors of Production and Factors Markets in Islamic Framework, *Journal of King AbdulAziz University: Islamic Economics*, Vol. 2, pp. 25-45.
- Mustafa, Ahmad H. and Askari, Hossein G. (1988)** "The Economic Implications of Land Ownership and Land Cultivation in Islam," in: **Munawar Iqbal (editor)**, *Distributive Justice and Need fulfillment in an Islamic Economy*, International Institute of Islamic Economics, Islamabad and The Islamic Foundation, Leicester, U.K., pp. 91-145.
- Nomani, Farhad and Rahnama, Ali (1994)** *Islamic Economic Systems*, Zed Books Ltd., London and New Jersey.
- Oser, Jacob and Brue, Stanley L. (1988)** *The Evolution of Economic Thought*, Fourth Edition, Harcourt Brace Jvanovich Publishers, New York.
- Parker, David and Stead, Richard (1991)** *Profit and Enterprise: the Political economy of Profit*, Harvester Wheatsheaf, U.K.
- Rahman, Afzalur, Economic Doctrines of Islam**, Vol. I, 1974, Vol. II, 1975, Vol. III, 1976, Islamic Publications Ltd., Lahore, Pakistan,
- Roll, Eric (1973)** *A History of Economic Thought*, Faber and Faber, London.
- Routh, G. (1980)** *Occupation and Pay in Great Britain, 1906-1979*, London, Macmillan.
- Samuels, W.J. "Institutional Economics" in: Greenaway, et. al. (1991)**
- Samuelson, P. (1980)** *Economics*, 11th edition, McGraw Hill, New York.
- Samuelson, P. and Nordhaus, William, D. (1985)** *Economics*, 12th edition, International Student edition, National Printers (Pte.) Ltd., Singapore.
- Sawyer, Malcolm C. "Post Keynesian Macroeconomics" in: Greenaway et. al. (1991)** pp. 184-206.
- Siddiqui, M.N. (1981)** *Muslim Economic Thinking: A Survey of Contemporary Literature*, The Islamic Foundation, U.K., and International Center for Research in Islamic Economics, King Abdul Aziz University, Jeddah.
- Siddiqui, Shamim, A. (1994)** "Some Controversies in Contemporary Macroeconomics: An Islamic Perspective", *Review of Islamic Economics*, Leicester, Volume 3, Number 1, pp. 19-50.



- Smith, Stephen W. (1994)** *Labour Economics*, Routledge Publications, London.
- Spiegel, William H. (1991)** *The Growth of Economic Thought*, Third Edition, Duke University Press, Durham & London.
- Staley, Charles A. (1989)** *A History of Economic Thought: From Aristotle to Arrow*, Oxford, UK, and Cambridge, Massachusetts, USA, Blackwell.
- Stigler, George J. (1987)** *The Theory of Price*, 4th edition, Macmillan Publishing Company, New York & London.
- Stirati, Antonella (1994)** *The Theory of Wages in Classical Economics: A Study of Adam Smith, David Ricardo and Their Contemporaries*, Aldershot, Hants, England and Bookfield, Vermont, USA. Edward Elgar.

## عناصر الإنتاج وعوائدها في الاقتصاد السياسي الإسلامي

شميم أحمد صديقي

أستاذ مساعد ، جامعة برونائي - دار السلام

**المستخلص :** تلقي هذه الورقة نظرة نقدية على تعريفات عناصر الإنتاج وتصنيفها وكيفية تحديد عوائدها في إطار النظرية الاقتصادية النيوكلاسيكية، كما تتناول هذه الورقة بالتحليل بعض التعديلات المقترحة على تلك التعريفات من قبل بعض الاقتصاديين المسلمين .

وتناقش قضايا ملكية الأرض وإجارتها ومزارعتها من منظور تاريخي وإسلامي . وتحاول التأليف بين النظريات المتزاخمة لعرض العمل والطلب عليه وتحديد الأجور . كما تناقش موضوع رأس المال المادي والنقدي في السياق التقليدي والإسلامي .

وتختتم الورقة بتأكيد دور المستحدث (صاحب المشروع) وبخاصة في نظام اقتصادي إسلامي .